





**ESSENTIAL™
WELLNESS
SHIELDS**



HOWARD INDUSTRIES
PRIME SIGN PROGRAM
Planning • Resources • Installation • Manufacturing • Execution

SGuard Catalog

primesignprogram.com

877.468.7000   

SGUARD STANDARD MODELS

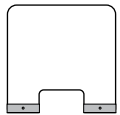
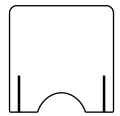
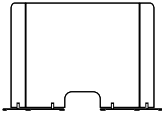

Portable Models With Access Window

Section 1: SG-W	
	A single piece of acrylic with a radius or square window (standard) that allows access to either side. The base is 2" aluminum angle on each side, to provide support. p. 5
Section 2: SG-FW	
	Requires no tools to assemble. This Guard has 2 acrylic feet that allow it to stand on it's own. Radius or square window (standard) that allows access to either side. p. 14
Section 3: SG-AW	
	3 sided bent back acrylic, with solid aluminum base and standoffs allow for a raised look off counter. Radius or square window (standard) that allows for access on either side. p. 19

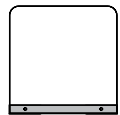
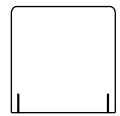
Portable Models Without Window

Section 1: SG	
	A single piece of acrylic with a 2" aluminum angle base on each side to provide support. p. 22
Section 2: SG-F	
	Requires no tools to assemble. This Guard has 2 acrylic feet that allow it to stand on it's own. p. 24

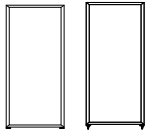
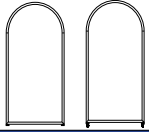
Free Standing Models

Section 1: SG-FR • SG-FRW	
	Designed to stand on the floor, they divide spaces that have no table-tops. Sturdy HED-100 beveled aluminum frame, with the option of wheels for easy mobility. Graphics optional. p. 26
Section 2: SG-RFR • SG-RFRW	
	Designed to stand on the floor, they divide spaces that have no table-tops. Sturdy HED-100 beveled aluminum frame with a radius top and the option of wheels. Graphics optional. p. 27
Section 3: SG-RFRTW	
	Designed to stand on the floor, they divide spaces that have no table-tops. Sturdy HED-100 beveled aluminum frame with a radius top. The no-trip option of 3 wheels for easy mobility. Graphics optional. p. 28

"T" Shaped Teller Model with Window

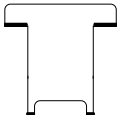
Section 1: SG-TW	
	Main use for inside of banks or credit unions with teller windows. Custom sizes for various counter heights. 4 extrusion pieces support the acrylic in the window, 2 on the top and 2 on the bottom. p. 29

SGUARD STANDARD MODELS

Stationary Models

Section 1: SG-CTB (Counter Mount)

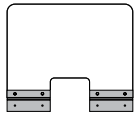

A single piece of acrylic with a radius or square window (standard) that allows access to either side. The mount is attached to the lip of a counter using bolts for stability and maximized space. p. 31

Section 2: SG-PM (Projection Mount)

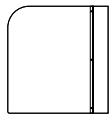

Designed to be fixed to a vertical surface with fasteners (not included). This allows installer to select custom height without compromising any counter space. p. 32

Section 3: SG-CM (Ceiling Mount)

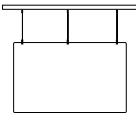

Suspended from the ceiling with durable cables and hardware (included), allowing select height and possible access underneath. This can also support a larger SGuard style. p. 33

Section 4: All Acrylic

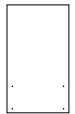

This SGuard is only the acrylic that is fastened to a preexisting surface. A simple method to installing that only requires screws (not included). p. 35

Section 5: SG-Cubicle

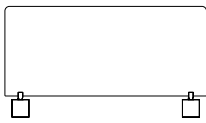

Attaches to the tops of cubicles in office spaces with a mounting bracket. p. 37

Table Top Models

Section 1: SG-TBLD (4 Sections)

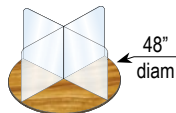

Requires no tools to assemble. 2 interlocking pieces create 4 separate sections on a table top. Radius or square corners with optional windows p. 38

Section 2: SG-TBLD (6 Sections)

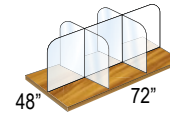

Requires no tools to assemble. 3 interlocking pieces create 6 separate sections on a table top. Radius or square corners with optional windows p. 40

Section 3: SG-TBLD (8 Sections)

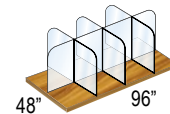

Requires no tools to assemble. 4 interlocking pieces create 8 separate sections on a table top. Radius or square corners with optional windows p. 41

Vehicle Models

Section 1: SUV

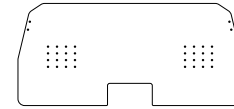

Designed to fit most models of Sports Utility Vehicles to allow driver and passenger protection. Pre-drilled installation grid allows for easy installation. Made from 1/8" polycarbonate. p. 42

Section 2: Car

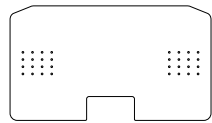

Designed to fit most models of Sedan styled cars. Pre-drilled installation grid allows for easy installation. Made from 1/8" polycarbonate. p. 44

Section 3: Truck

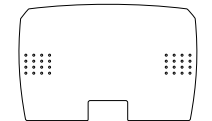

Designed to fit most models of Trucks to allow driver and passenger protection. Pre-drilled installation grid allows for easy installation. Made from 1/8" polycarbonate. p. 46

Section 4: Mini Van

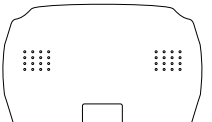

Designed to fit most models of Mini Vans. Pre-drilled installation grid allows for easy installation. Made from 1/8" polycarbonate. p. 47

SGUARD FEATURES AND OPTIONS

MATERIALS:

The SGuard features 1/4" thick heavy duty, crystal clear cast acrylic. This material provides chemical resistance to allow for cleaning and disinfecting without the concern of cracking, hazing, or clouding of the viewing surface.

OPTIONAL:

CORNERS: Radius or square corners can be created on any SGuard with no added charge.

WINDOWS: Access windows to your customized sizes with no additional cost.

GRAPHICS: Logos, designs, and colored borders can be printed on all SGuard acrylic surfaces. Fee depends on area of applicable graphics

STANDARD BASES

Angled

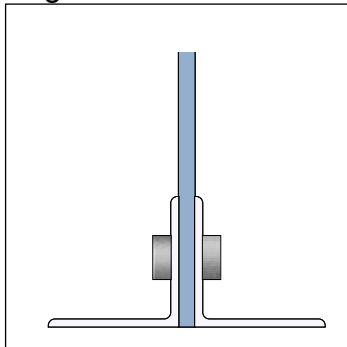

Acrylic Feet

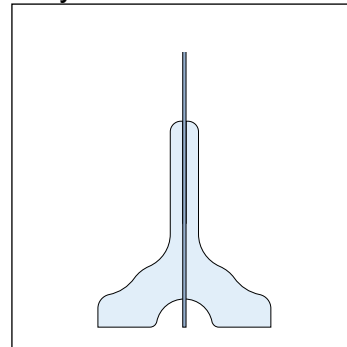

Flat

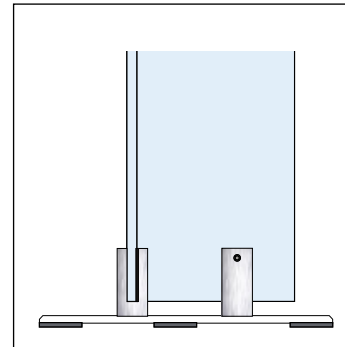

Cubicle Mount

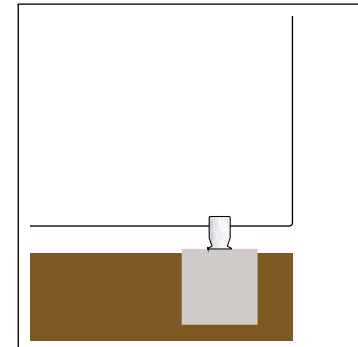





**ESSENTIAL™
WELLNESS
SHIELDS**

PORTABLE MODELS WITH ACCESS WINDOW

Section 1: SG-W (angled base)

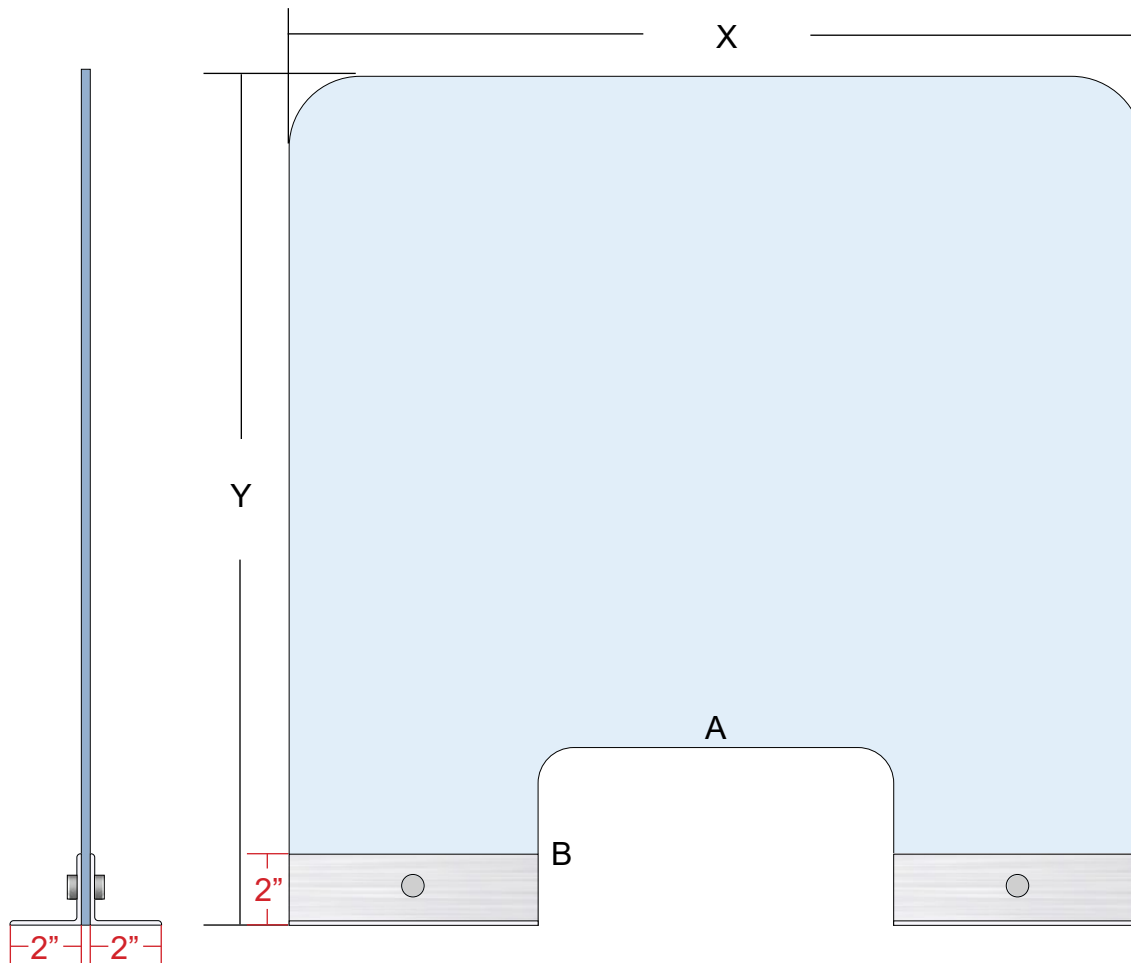
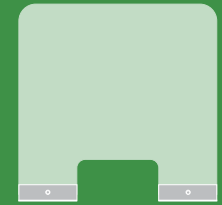

STANDARD SIZES:

Drawing (#)	Height (Y)	Length (X)	Window Height (B)	Window Length (A)
SG-2424-W	24"	24"	5"	10"
SG-2432-W	24"	32"	5"	10"
SG-3224-W	32"	24"	5"	10"
SG-3232-W	32"	32"	5"	10"
SG-2436-W	24"	36"	5"	10"
SG-3242-W	32"	42"	5"	10"
SG-3048-W	30"	48"	3"	15"
SG-3624-W	36"	24"	5"	10"
SG-3220-W	32"	20"	5"	10"
SG-2830-W	28"	30"	5"	10"
SG-4830-W	48"	30"	5"	10"
SG-2836-W	28"	36"	5"	10"
SG-3648-W	36"	48"	5"	10"
SG-3054-W	30"	54"	5"	10"
SG-3141-W	31"	41"	5"	10"
SG-4044-W	40"	44"	5"	10"
SG-3236-W	32"	36"	5"	10"
SG-3632-W	36"	32"	5"	10"
SG-3636-W	36"	36"	5"	10"

Additional sizes available upon request up to 40" height.

For sizes 40" and higher.
3" angle replaces the 2" for the mounting base



**ESSENTIAL™
WELLNESS
SHIELDS**

PORTABLE MODELS WITH ACCESS WINDOW

Section 1: SG-W (angled base)

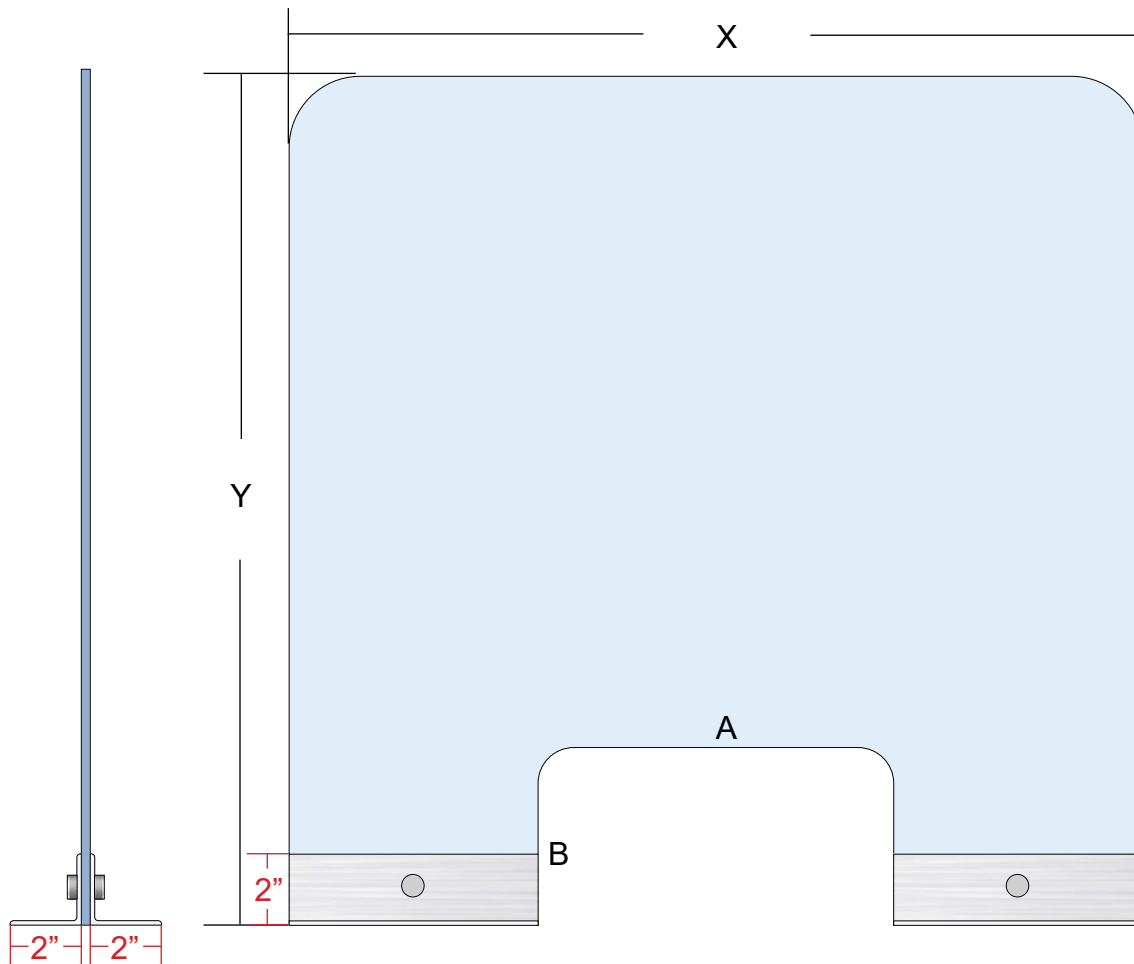
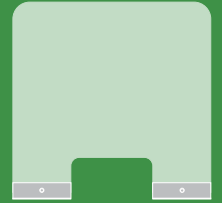

AVAILABLE SIZES:

Drawing (#)	Height (Y)	Length (X)	Window Height (B)	Window Length (A)
SG-3248-W	32"	48"	5"	10"
SG-3636-1-3X15W0	36"	36"	3"	15"
SG-3260-3X15W0	32"	60"	3"	15"
SG-2472-W3X12	24"	72"	3"	12"
SG-3624-W3X12	36"	24"	3"	12"
SG-3248-W810	32"	48"	8"	10"
SG-2460-W3X12	24"	60"	3"	12"
SG-3628-W3X12	36"	28"	3"	12"
SG-2432-W3X12	24"	33"	3"	12"
SG-3628-W3X12	36"	28"	3"	12"
SG-1830-321810-W	18"	30"	8"	10"
SG-3232-321850-W	32"	32"	3"	10"

Additional sizes available upon request up to 40" height.

For sizes 40" and higher.
3" angle replaces the 2" for the mounting base



**ESSENTIAL™
WELLNESS
SHIELDS**

PORTABLE MODELS WITH ACCESS WINDOW

Section 1: SG-W (angled base)

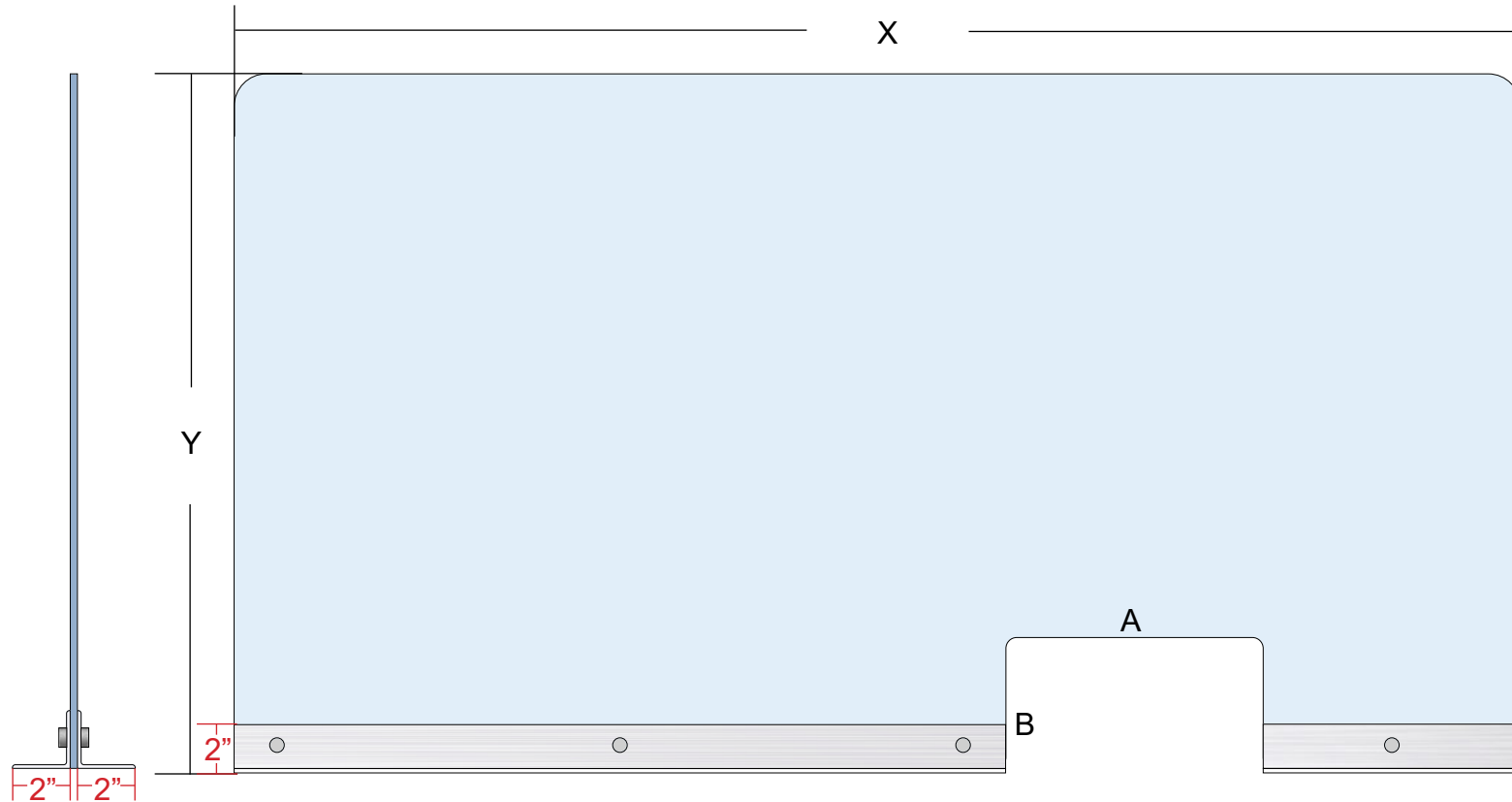
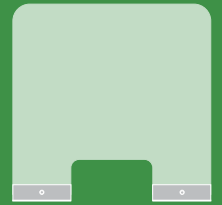

Additional sizes available upon request up to 40" height.

For sizes 40" and higher.
3" angle replaces the 2" for the mounting base

STANDARD SIZES:

Drawing (#)	Height (Y)	Length (X)	Window Height (B)	Window Length (A)
SG-3260-W612-R	32"	60"	6"	12"



**ESSENTIAL™
WELLNESS
SHIELDS**

PORTABLE MODELS WITH ACCESS WINDOW

Section 1: SG-W (angled base)

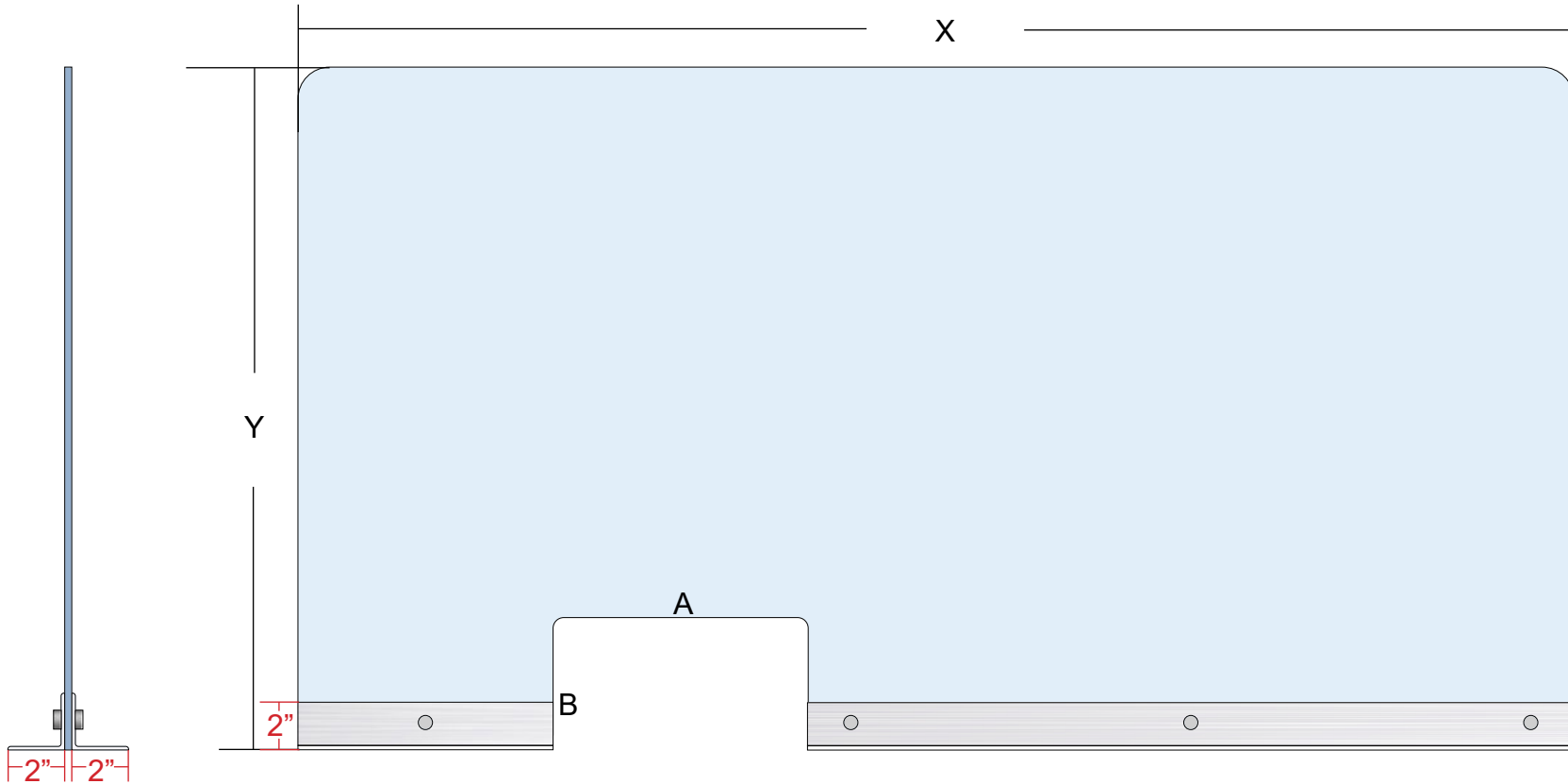
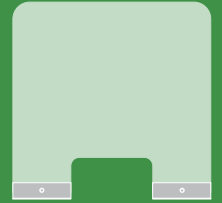

STANDARD SIZES:

Drawing (#)	Height (Y)	Length (X)	Window Height (B)	Window Length (A)
SG-3260-W612-L	32"	60"	6"	12"
SG-3256-W612-L	32"	56"	6"	12"
SG-3248-WL	32"	48"	10"	10"
SG-3682-W	36"	82"	5"	18"

Additional sizes available upon request up to 40" height.

For sizes 40" and higher.
3" angle replaces the 2" for the mounting base



**ESSENTIAL™
WELLNESS
SHIELDS**

PORTABLE MODELS WITH ACCESS WINDOW

Section 1: SG-W (angled base)

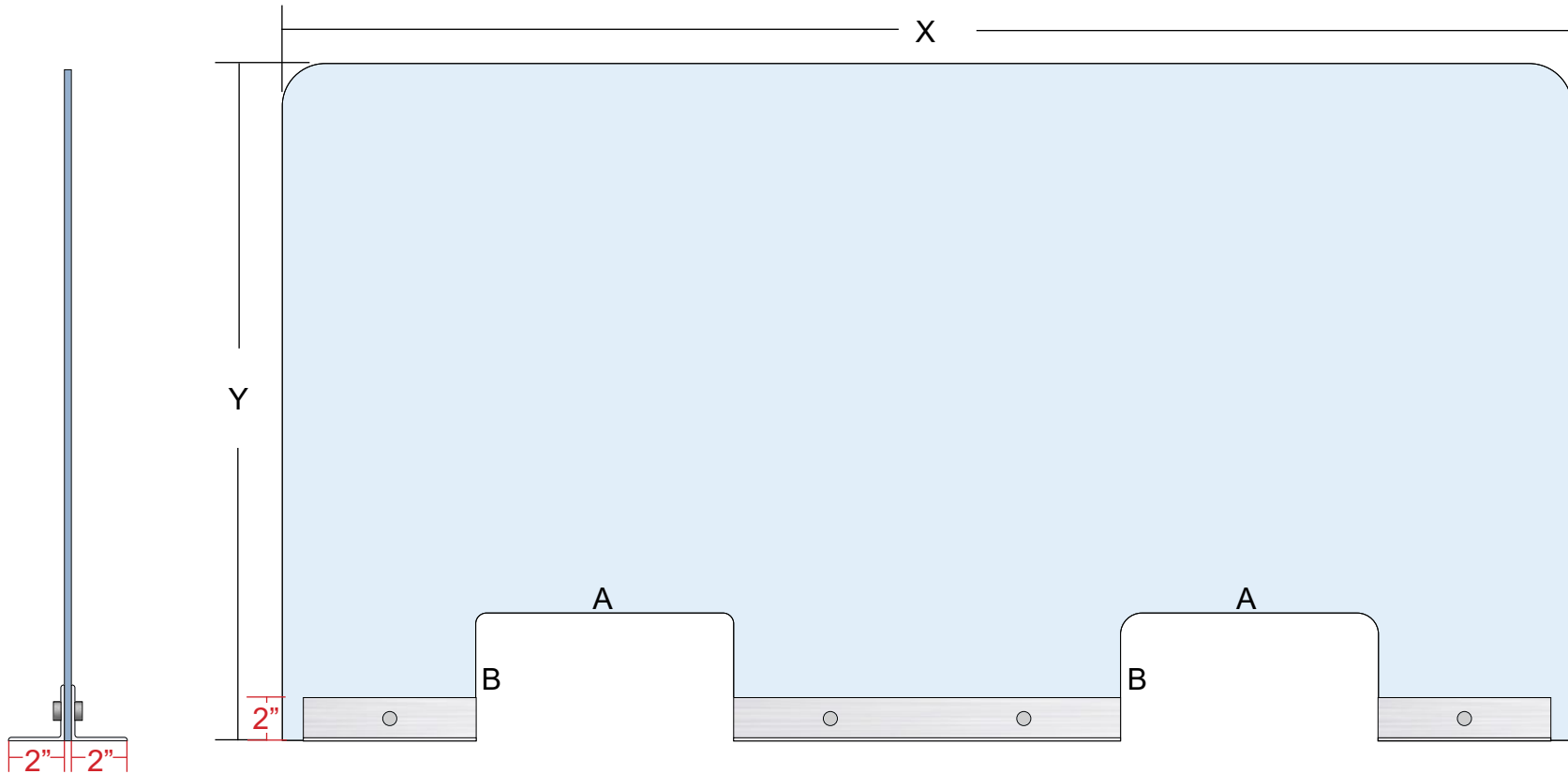

Additional sizes available upon request up to 40" height.

For sizes 40" and higher.
3" angle replaces the 2" for the mounting base

STANDARD SIZES:

Drawing (#)	Height (Y)	Length (X)	Window Height (B)	Window Length (A)
SG-3260-2W612	32"	60"	6"	12"



**ESSENTIAL™
WELLNESS
SHIELDS**

PORTABLE MODELS WITH ACCESS WINDOW

Section 1: SG-W (angled base)

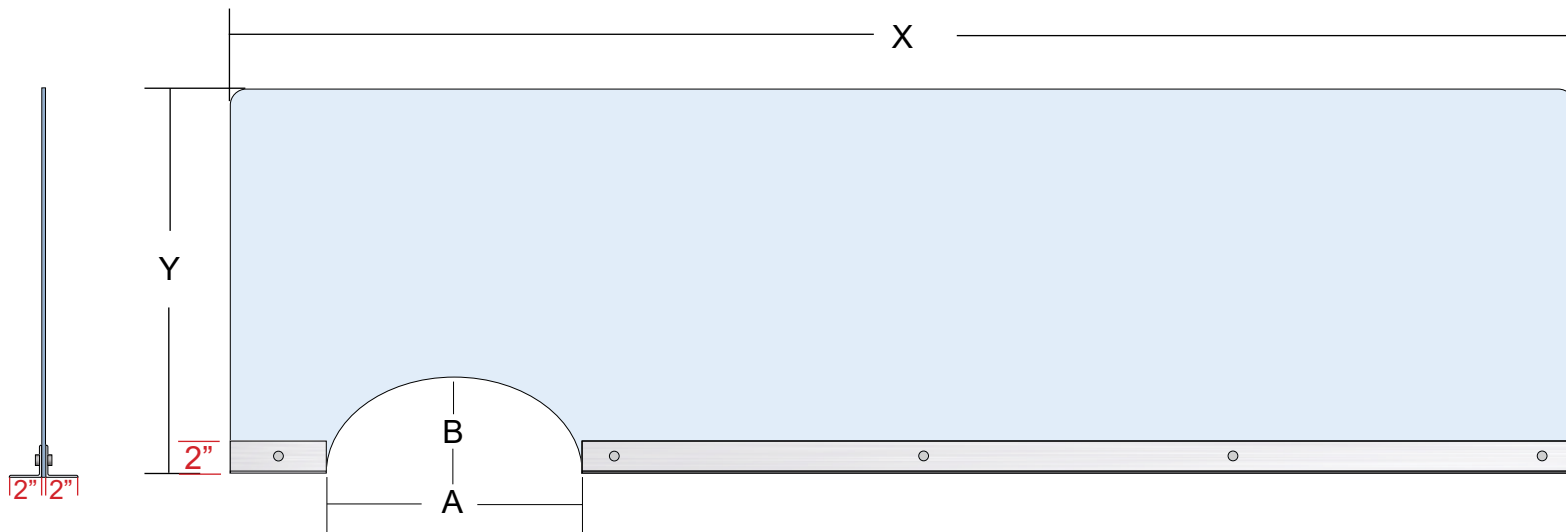

Additional sizes available upon request up to 40" height.

For sizes 40" and higher.
3" angle replaces the 2" for the mounting base

STANDARD SIZES:

Drawing (#)	Height (Y)	Length (X)	Window Height (B)	Window Length (A)
SG-8424-CMW	24"	84"	6"	16"



**ESSENTIAL™
WELLNESS
SHIELDS**

PORTABLE MODELS WITH ACCESS WINDOW

Section 1: SG-W (angled base)

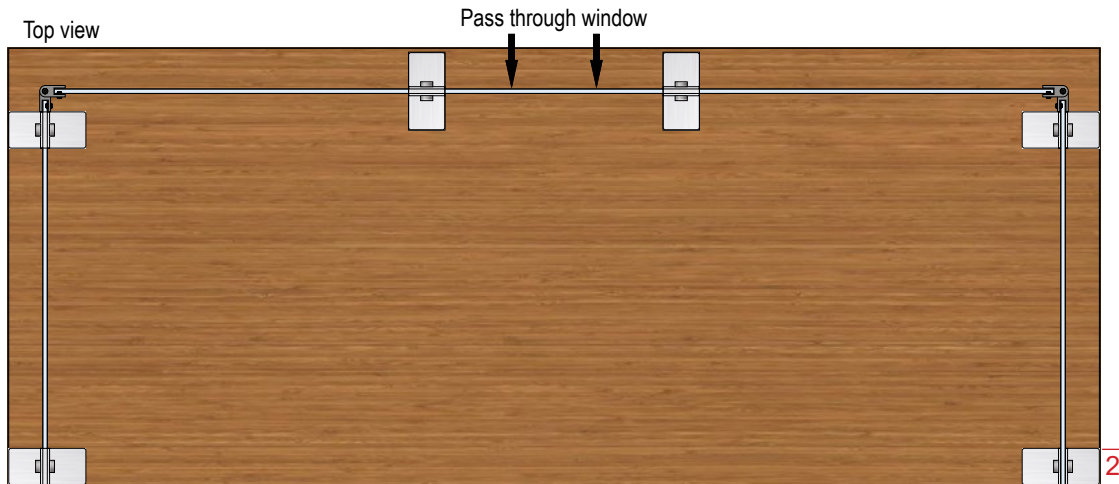

STANDARD SIZES:

Drawing (#)	Height (Y)	Length (X)	Window Height (B)	Window Length (A)
SG-5524-ADM	24"	55"	5"	12"

Additional sizes available upon request up to 40" height.

For sizes 40" and higher.
3" angle replaces the 2" for the mounting base

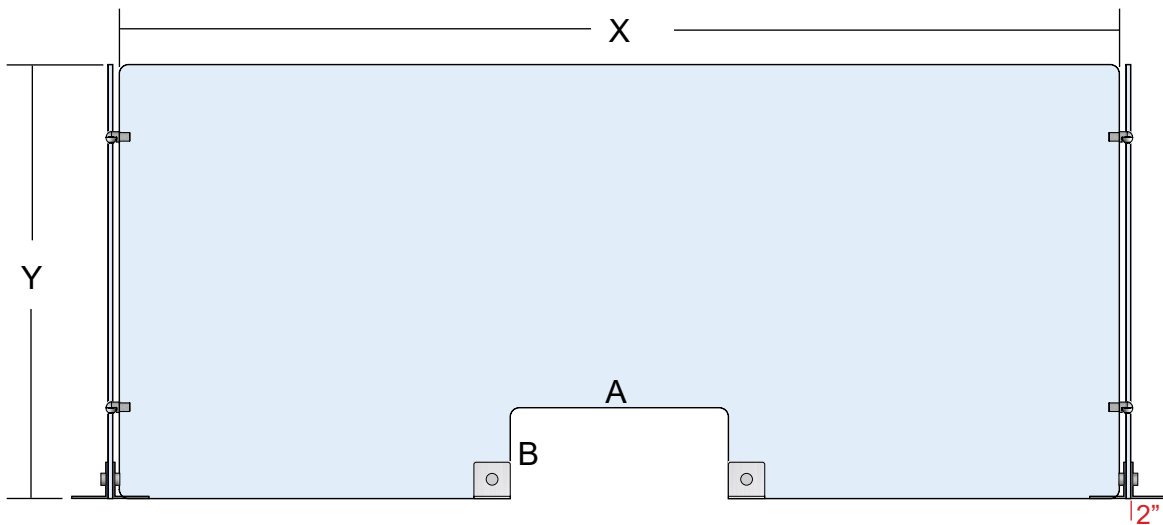



**ESSENTIAL
WELLNESS
SHIELDS**

PORTABLE MODELS WITH ACCESS WINDOW

Section 1: SG-W (angled base)

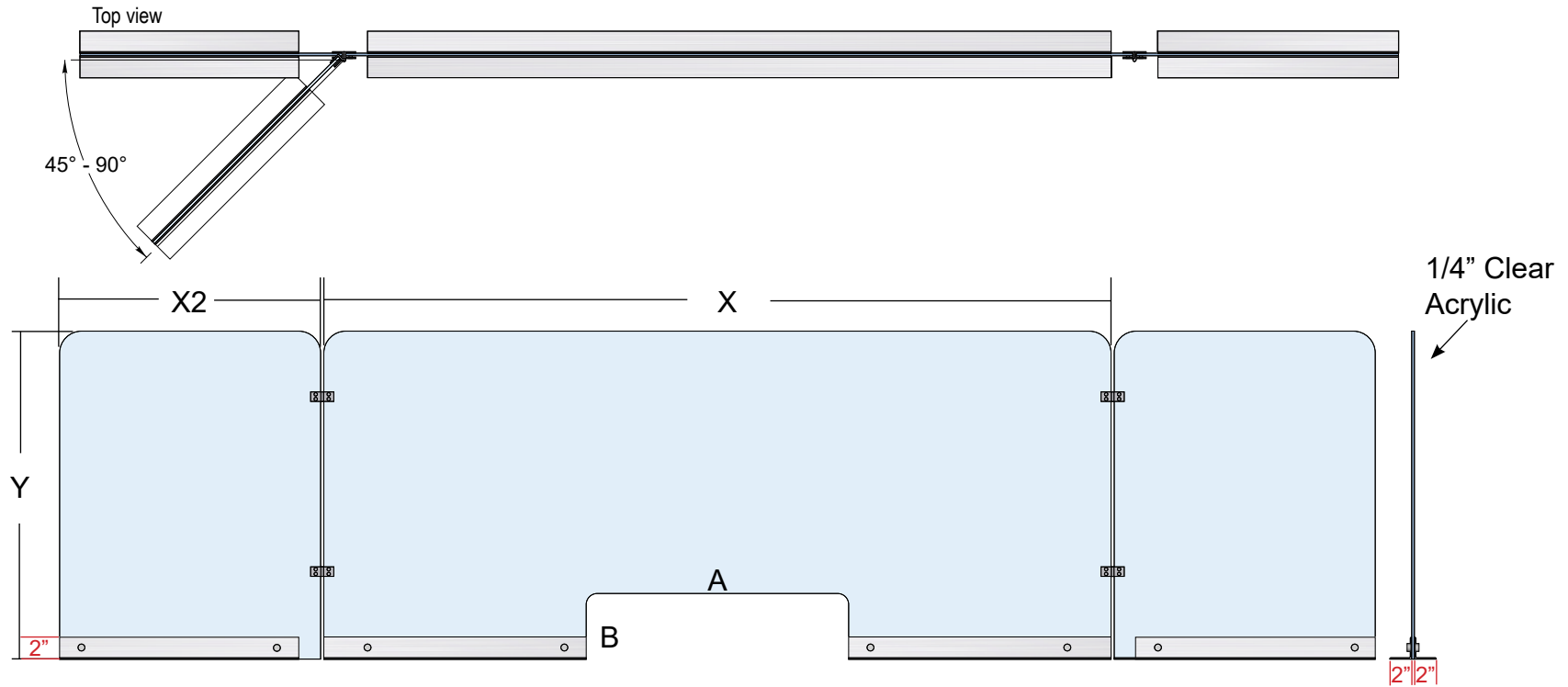
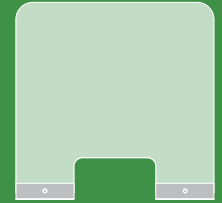

Additional sizes available upon request up to 40" height.

For sizes 40" and higher.
3" angle replaces the 2" for the mounting base

STANDARD SIZES:

Drawing (#)	Height (Y)	Length (X)	Length (X2)	Window Height (B)	Window Length (A)
SG-3072-ADMW	30"	72"	24"	6"	24"



**ESSENTIAL
WELLNESS
SHIELDS**

PORTABLE MODELS WITH ACCESS WINDOW

Section 1: SG-W (angled base)

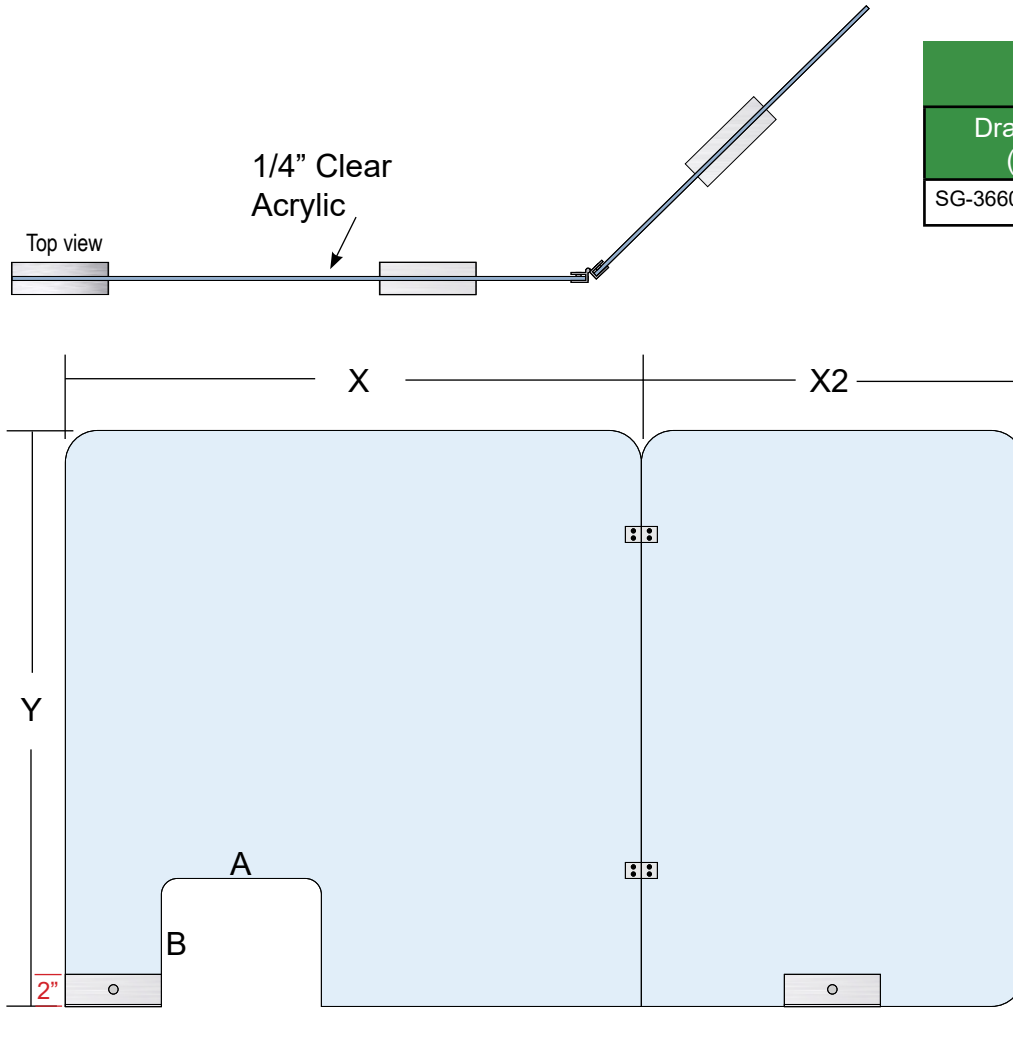
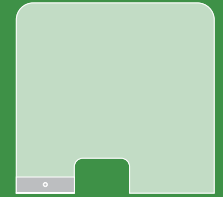

STANDARD SIZES:

Drawing (#)	Height (Y)	Length (X)	Length (X2)	Window Height (B)	Window Length (A)
SG-3660-HW	36"	36"	24"	8"	10"

Additional sizes available upon request up to 40" height.

For sizes 40" and higher.
3" angle replaces the 2" for the mounting base



**ESSENTIAL™
WELLNESS
SHIELDS**

PORTABLE MODELS WITH ACCESS WINDOW

Section 2: SG-FW (*acrylic feet*)

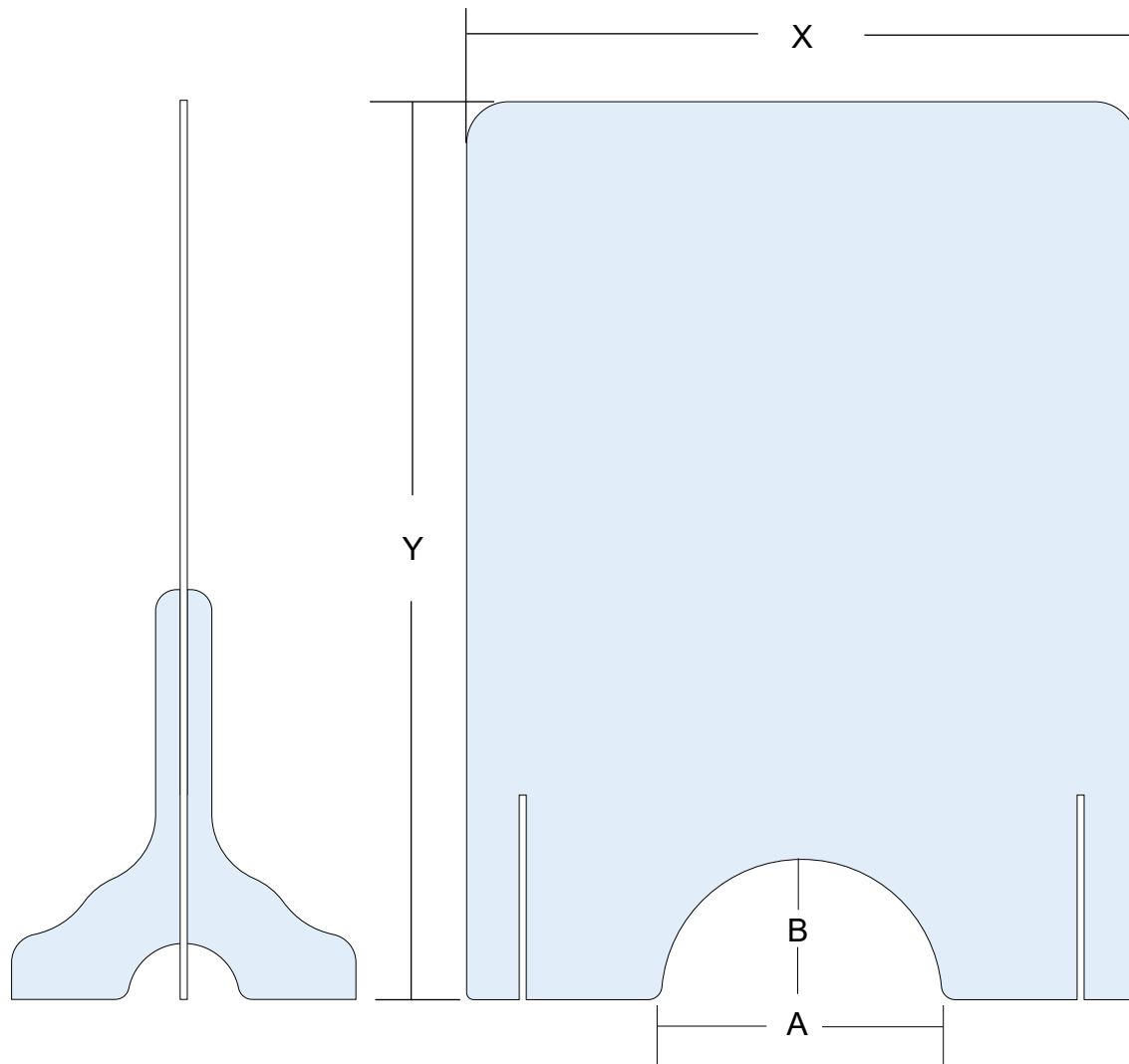
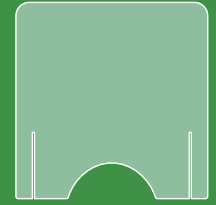

STANDARD SIZES:

Drawing (#)	Height (Y)	Length (X)	Window Height (B)	Window Length (A)
SG-3224-FW	32"	24"	5"	10"
SG-2465-FW	24"	65"	5"	10"
SG-2424-FW	24"	24"	5"	10"
SG-2228-FW	22"	28"	4"	10"
SG-4040-FW	40"	40"	4"	10"

Additional sizes available upon request up to 40" height.



**ESSENTIAL™
WELLNESS
SHIELDS**

PORTABLE MODELS WITH ACCESS WINDOW

Section 2: SG-FW (acrylic feet)

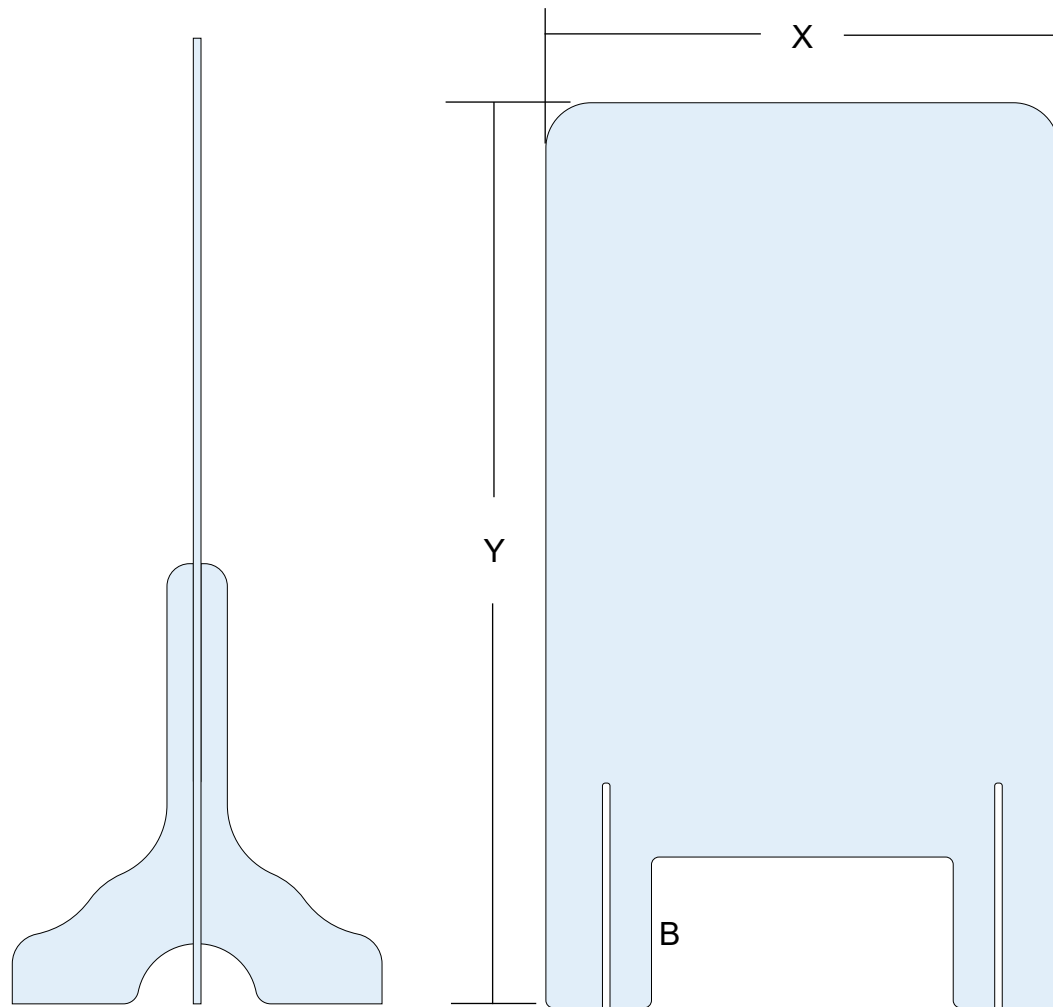
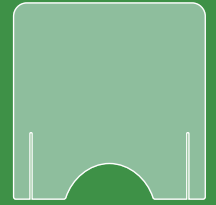

STANDARD SIZES:

Drawing (#)	Height (Y)	Length (X)	Window Height (B)	Window Length (A)
SG-3230-FW	32"	30"	5"	10"
SG-2460-FW	24"	60"	5"	10"
SG-3217-FW	32"	17"	5"	9"
SG-3219-FW	32"	19"	5"	10"
SG-3648-FW	36"	48"	5"	10"
SG-3636-FW	36"	36"	7"	12"
SG-3624-FW	36"	24"	6"	10"
SG-3221-FW	32"	21"	5"	10"
SG-2028-FW	20"	28"	4"	10"
SG-2026-FW	20"	26"	4"	10"
SG-2432-FW	24"	32"	5"	10"
SG-3216-FW	32"	16"	5"	8"
SG-3232-FW	32"	32"	7"	12"
SG-3045-FW	30"	45"	5"	10"
SG-3236-FW	32"	36"	5"	10"
SG-3224-FW2	32"	24"	5"	10"

Additional sizes available upon request up to 40" height.



**ESSENTIAL™
WELLNESS
SHIELDS**

PORTABLE MODELS WITH ACCESS WINDOW

Section 2: SG-FW (*acrylic feet*)

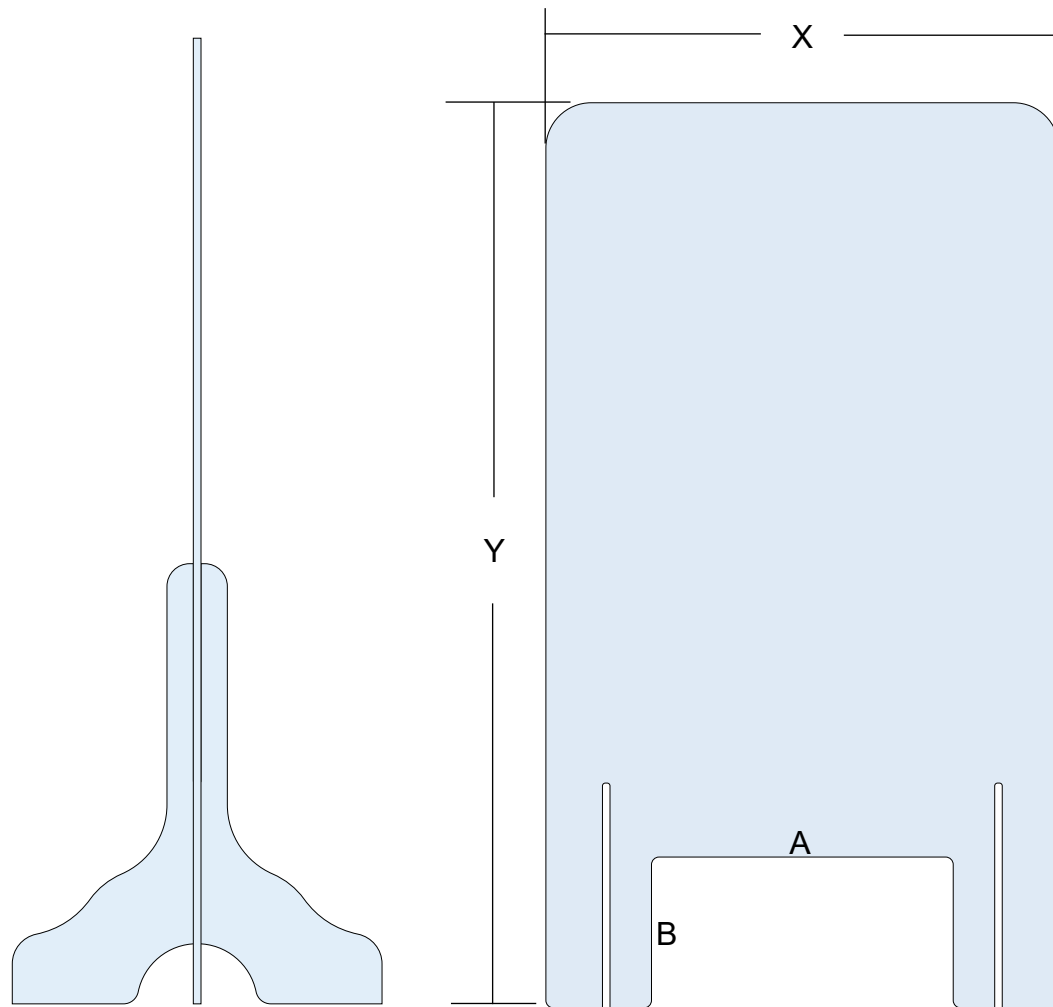
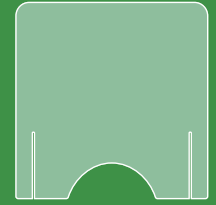

STANDARD SIZES:

Drawing (#)	Height (Y)	Length (X)	Window Height (B)	Window Length (A)
SG-3248-FW	32"	48"	5"	10"
SG-3268-FW	32"	68"	5"	10"
SG-4048-FW	40"	48"	5"	10"
SG-2642-FW	26"	42"	6"	16"
SG-3017-FW	30"	17"	5"	10"
SG-2430-FW	24"	30"	5"	10"
SG-3022-75-FW	30"	22"	5"	10"
SG-3017-5-FW	30"	17"	5"	10"
SG-3224-FW8X9	32"	24"	8"	9"
SG-2432-FW3X12	24"	32"	3"	12"
SG-3236-FW10X10	32"	36"	5"	10"
SG-2460-FW3X12	24"	60"	3"	12"
SG-3624-FW3X12	36"	24"	3"	12"
SG-2472-FW3X12	24"	72"	3"	12"
SG-3628-FW3X12	36"	28"	3"	12"
SG-3224-FW-NG	32"	24"	5"	10"

Additional sizes available upon request up to 40" height.



**ESSENTIAL™
WELLNESS
SHIELDS**

PORTABLE MODELS WITH ACCESS WINDOW

Section 2: SG-FW (acrylic feet)

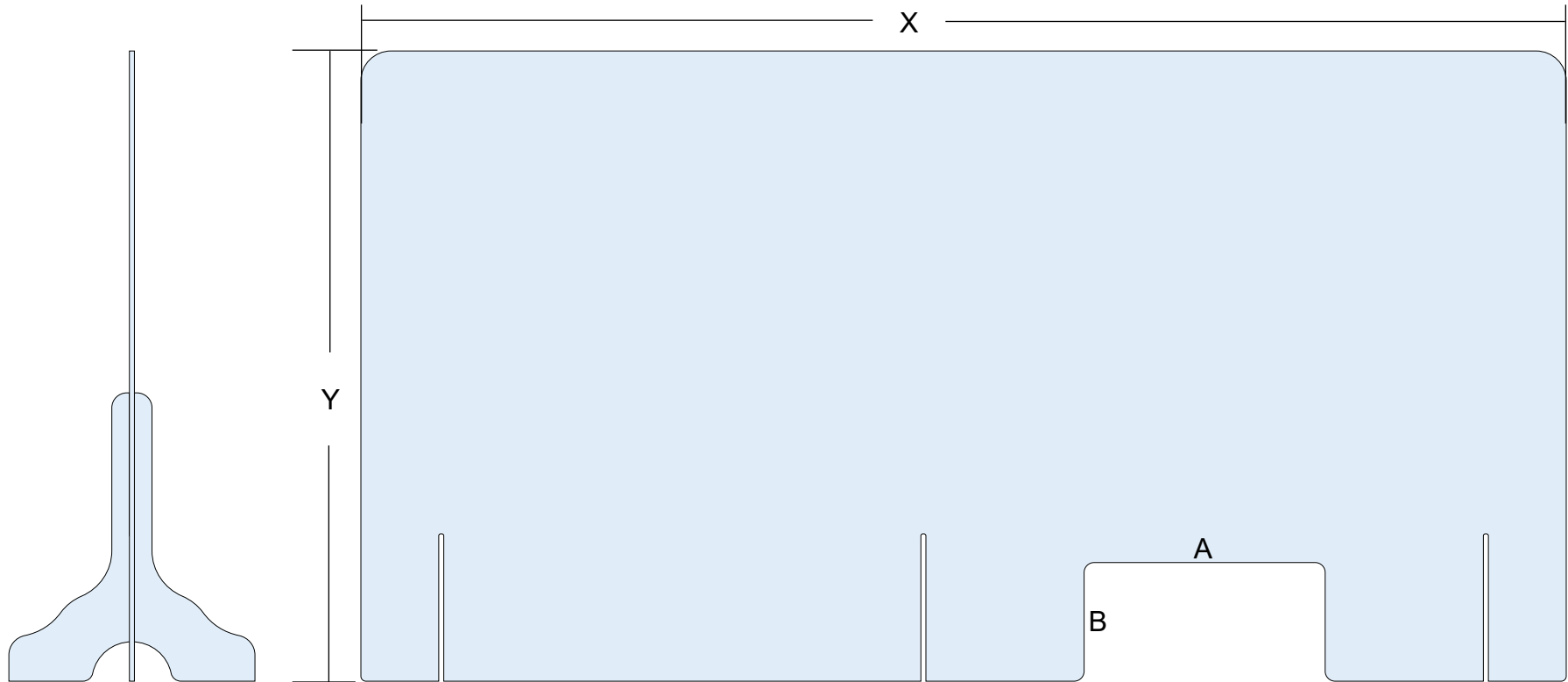
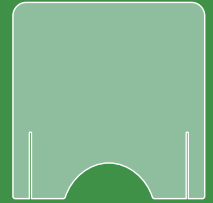

STANDARD SIZES:

Drawing (#)	Height (Y)	Length (X)	Window Height (B)	Window Length (A)
SG-3260-FW612-R	32"	60"	6"	12"

Additional sizes available upon request up to 40" height.



**ESSENTIAL™
WELLNESS
SHIELDS**

PORTABLE MODELS WITH ACCESS WINDOW

Section 2: SG-FW (*acrylic feet*)

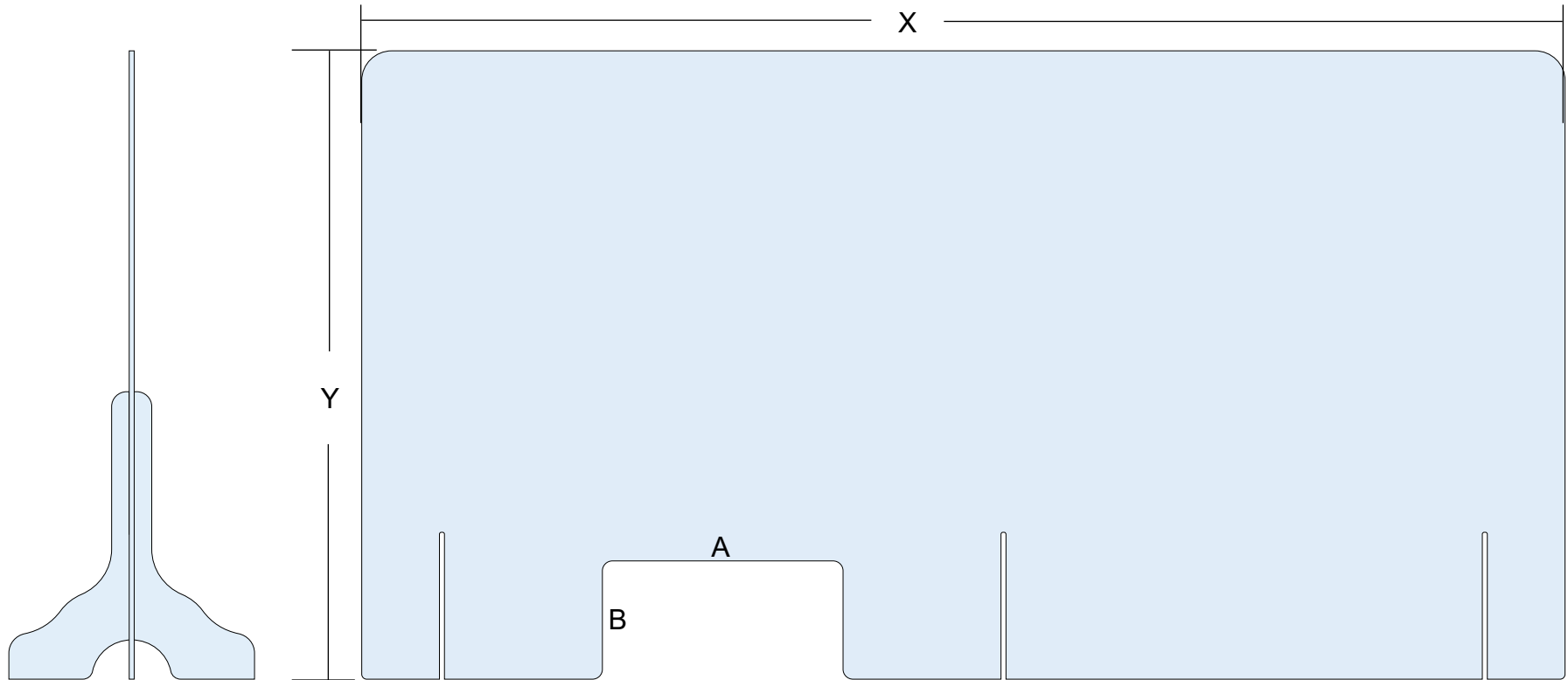
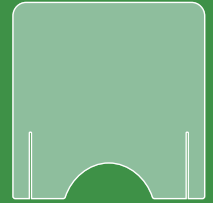

STANDARD SIZES:

Drawing (#)	Height (Y)	Length (X)	Window Height (B)	Window Length (A)
SG-3260-FW612-L	32"	60"	6"	12"

Additional sizes available upon request up to 40" height.



**ESSENTIAL™
WELLNESS
SHIELDS**

PORTABLE MODELS WITH ACCESS WINDOW

Section 3: SG-AW (flat base)

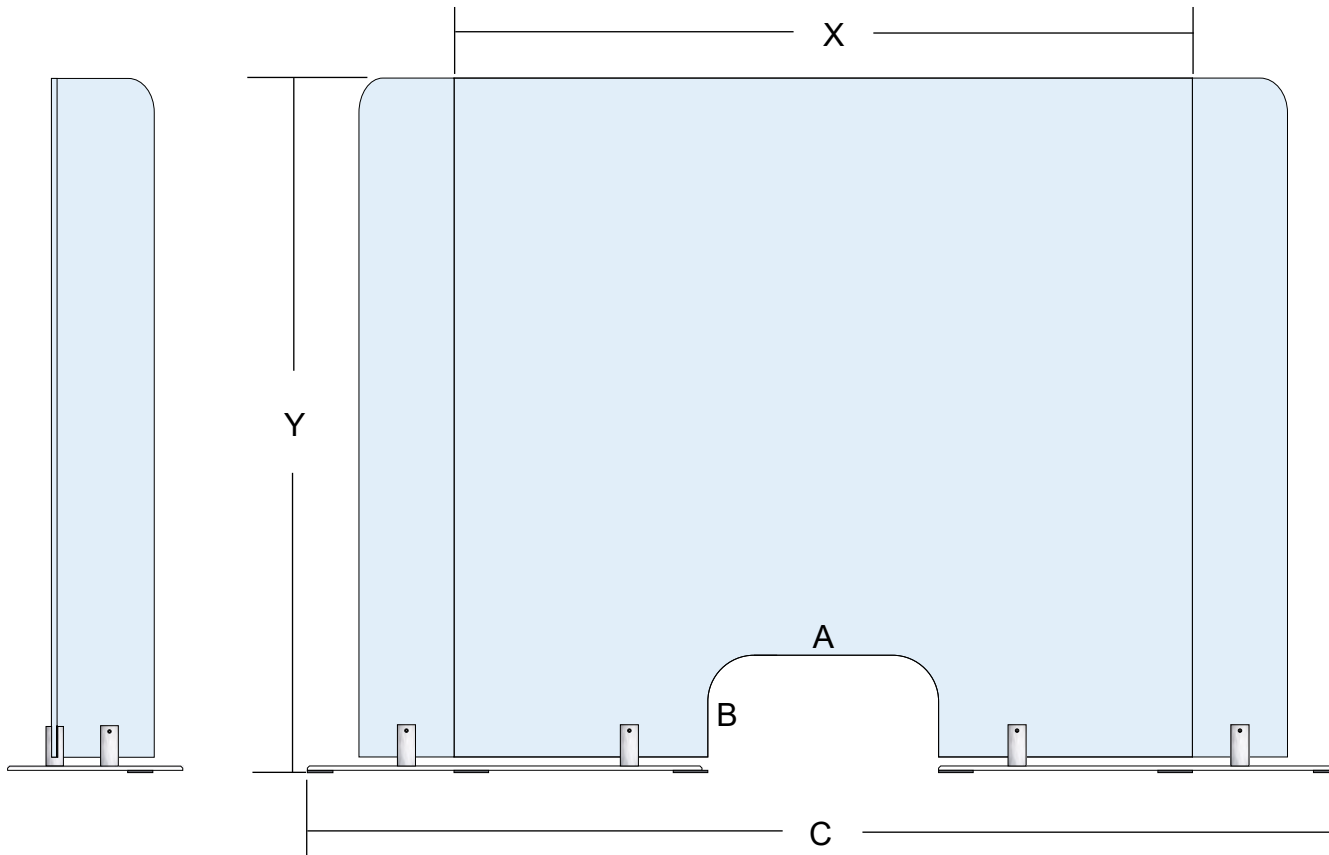
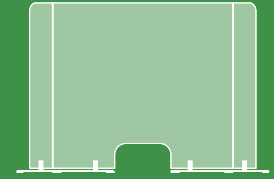

STANDARD SIZES:

Drawing (#)	Height (Y)	Length (X)	Window Height (B)	Window Length (A)	Overall Width (C)
SG-3141-AW	30"	32"	5"	10"	45"
SG-3648-AW	36"	37"	5"	19"	52"
SG-3541-AW	35"	30"	5"	12"	46"
SG-4041-AW	40"	18"	5"	12"	34"

Additional sizes available upon request up to 40" height.



**ESSENTIAL™
WELLNESS
SHIELDS**

PORTABLE MODELS WITH ACCESS WINDOW

Section 3: SG-AW (flat base)

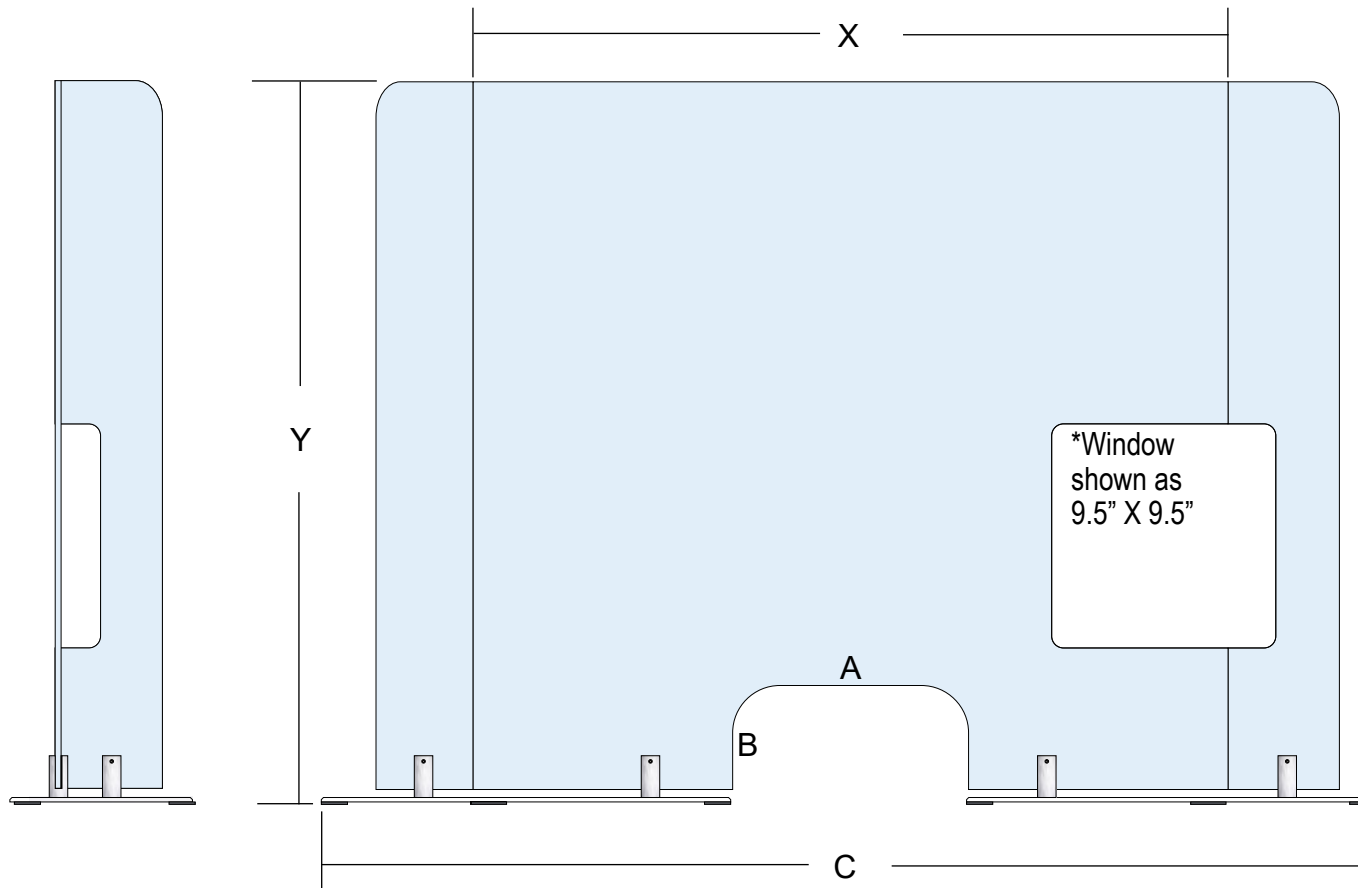

STANDARD SIZES:

Drawing (#)	Height (Y)	Length (X)	Window Height (B)	Window Length (A)	Overall Width (C)
SG-3141-A2W	30"	32"	5"	10"	45"

Additional sizes available upon request up to 40" height.



**ESSENTIAL
WELLNESS
SHIELDS**

PORTABLE MODELS WITH ACCESS WINDOW

Section 3: SG-AW (flat base)

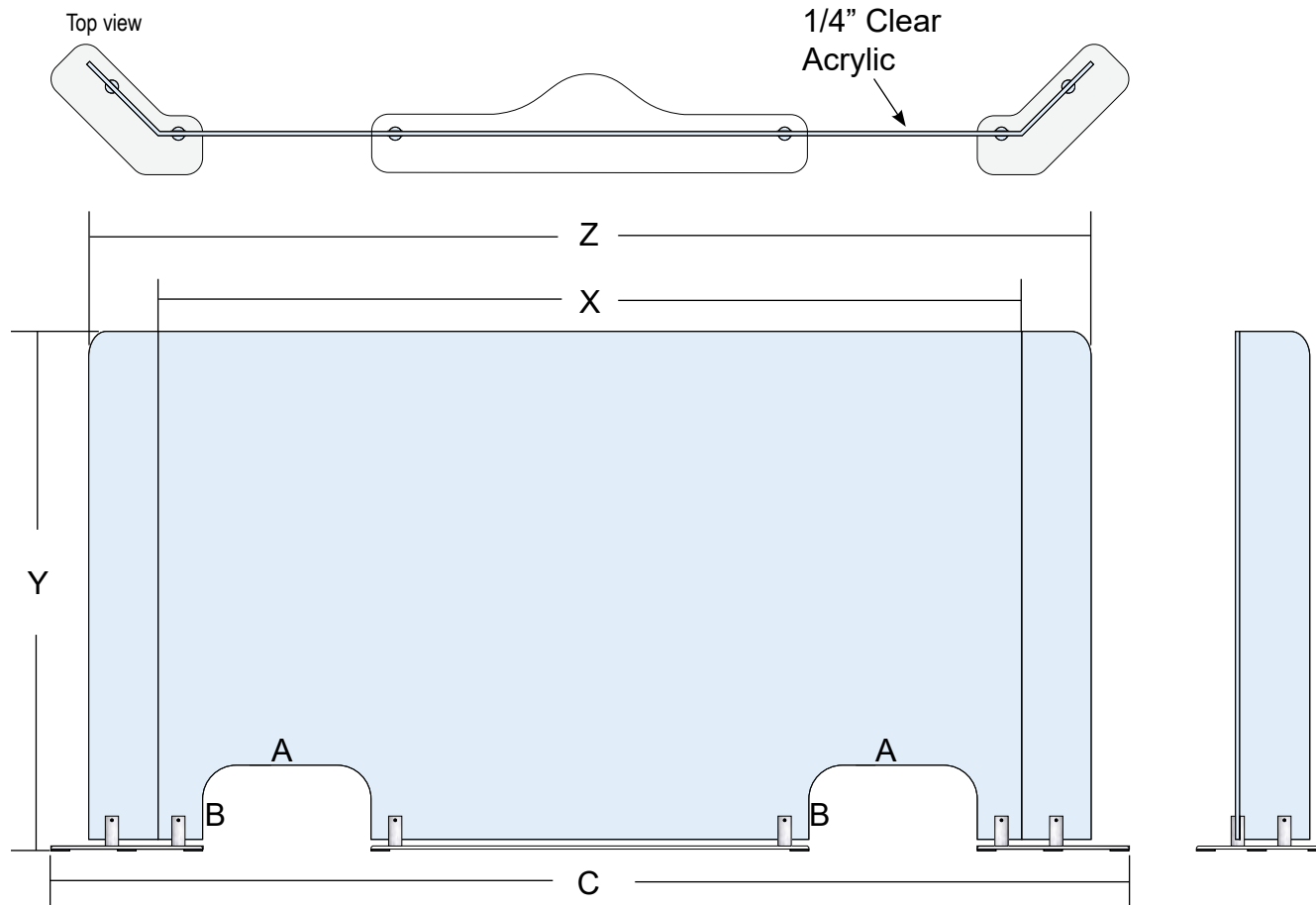
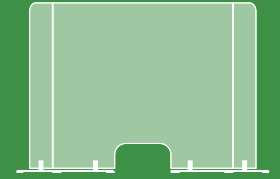

STANDARD SIZES:

Drawing (#)	Height (Y)	Length (X)	Length (Z)	Window Height (B)	Window Length (A)	Overall Width (C)
SG-3164-2-5X10-AW-0	31"	52"	59.5"	5"	10"	64"

Additional sizes available upon request up to 40" height.



**ESSENTIAL™
WELLNESS
SHIELDS**

PORTABLE MODELS WITH NO WINDOWS

Section 1: SG (angled base)

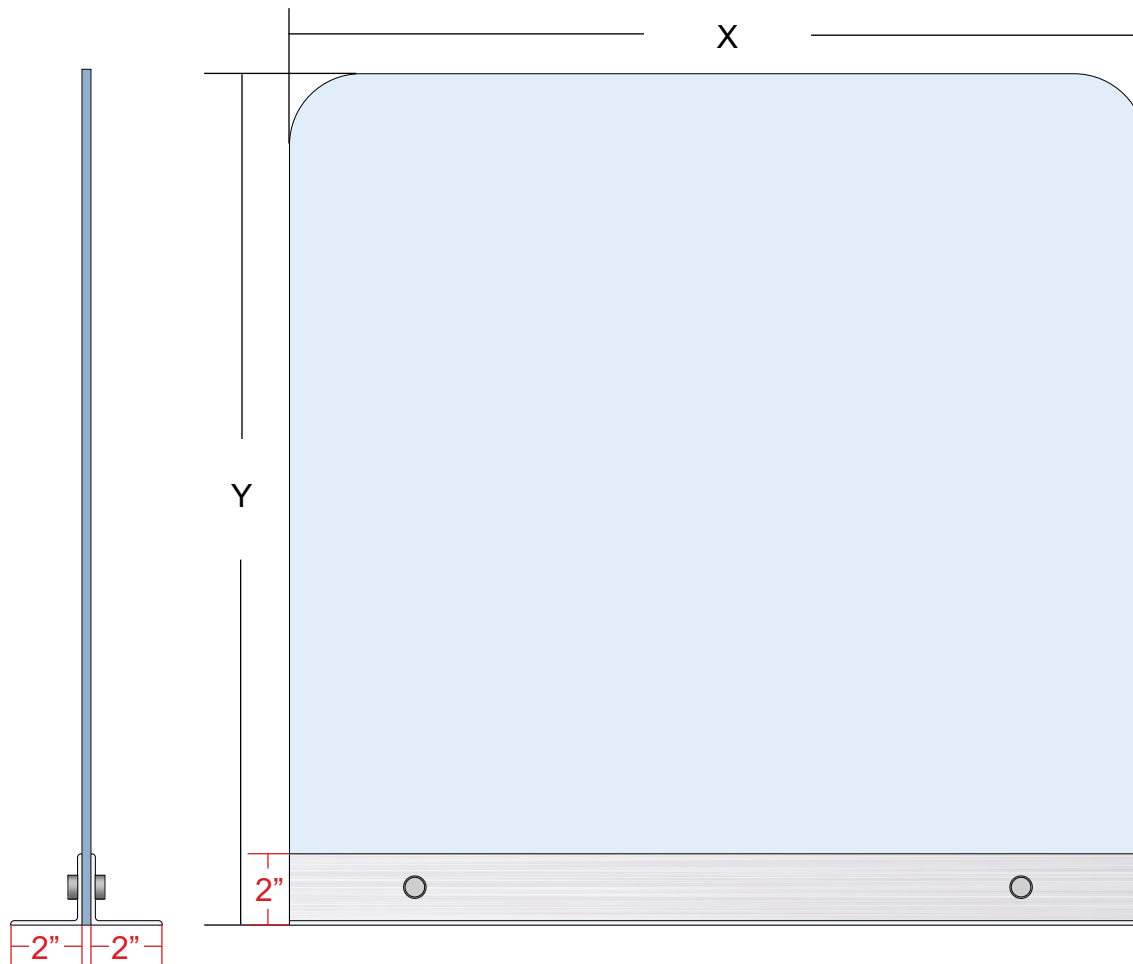
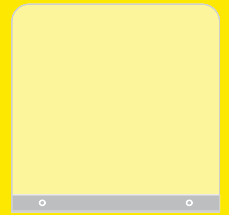

STANDARD SIZES:

Drawing (#)	Height (Y)	Length (X)
SG-3224	32"	24"
SG-2424	24"	24"
SG-3630	36"	30"
SG-1530	15.5"	30"
SG-3232	32"	32"
SG-3253-0-0x0ST-0	32"	53"
SG-4040	40"	40"
SG-2824	28"	24"

Additional sizes available upon request, up to 40" height.

For sizes 40" and higher.
3" angle replaces the 2" for the mounting base



**ESSENTIAL™
WELLNESS
SHIELDS**

PORTABLE MODELS WITH NO WINDOWS

Section 1: SG (angled base)

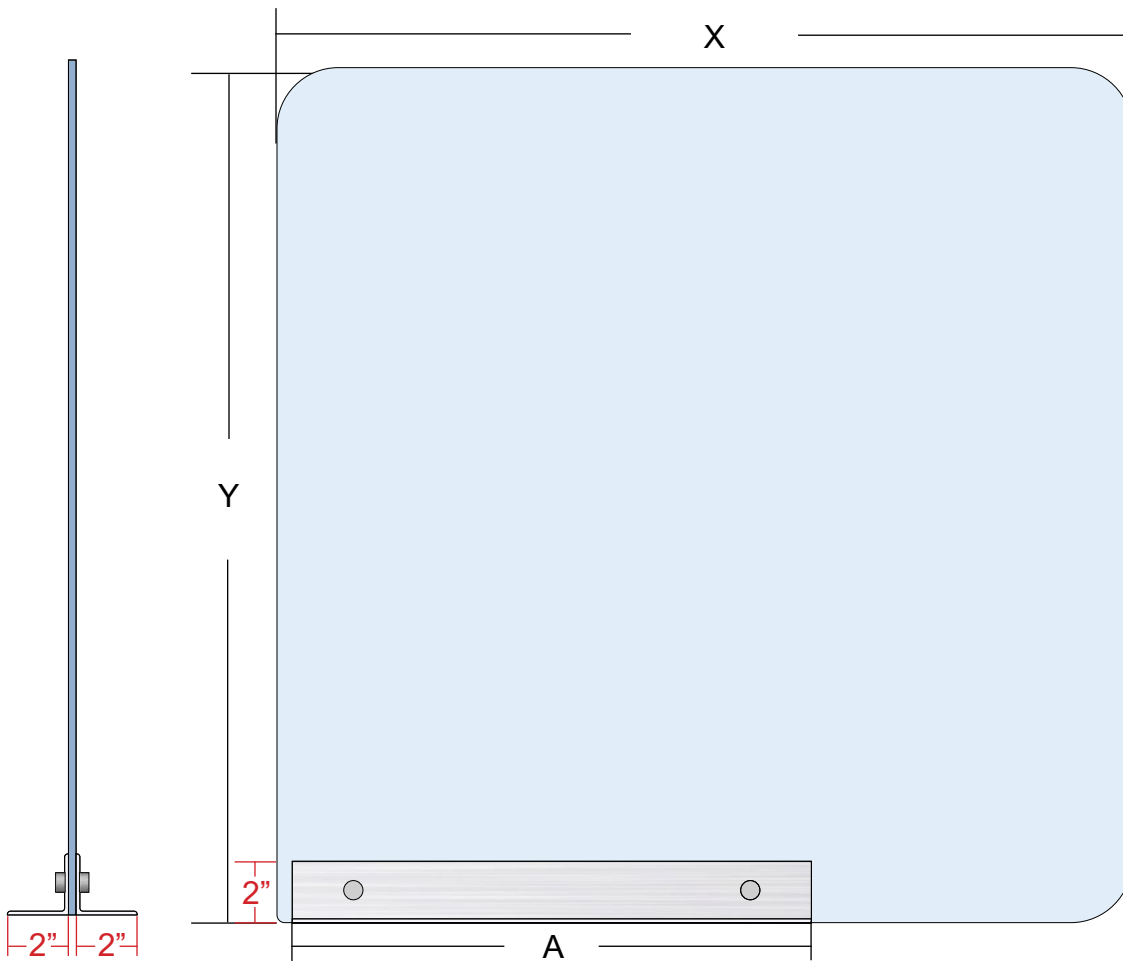

STANDARD SIZES:

Drawing (#)	Height (Y)	Length (X)	Length (A)
SG-2828-321851	28"	28"	15"

Additional sizes available upon request, up to 40" height.

For sizes 40" and higher.
3" angle replaces the 2" for the mounting base



**ESSENTIAL™
WELLNESS
SHIELDS**

PORTABLE MODELS WITH NO WINDOWS

Section 2: SG-F (*acrylic feet*)

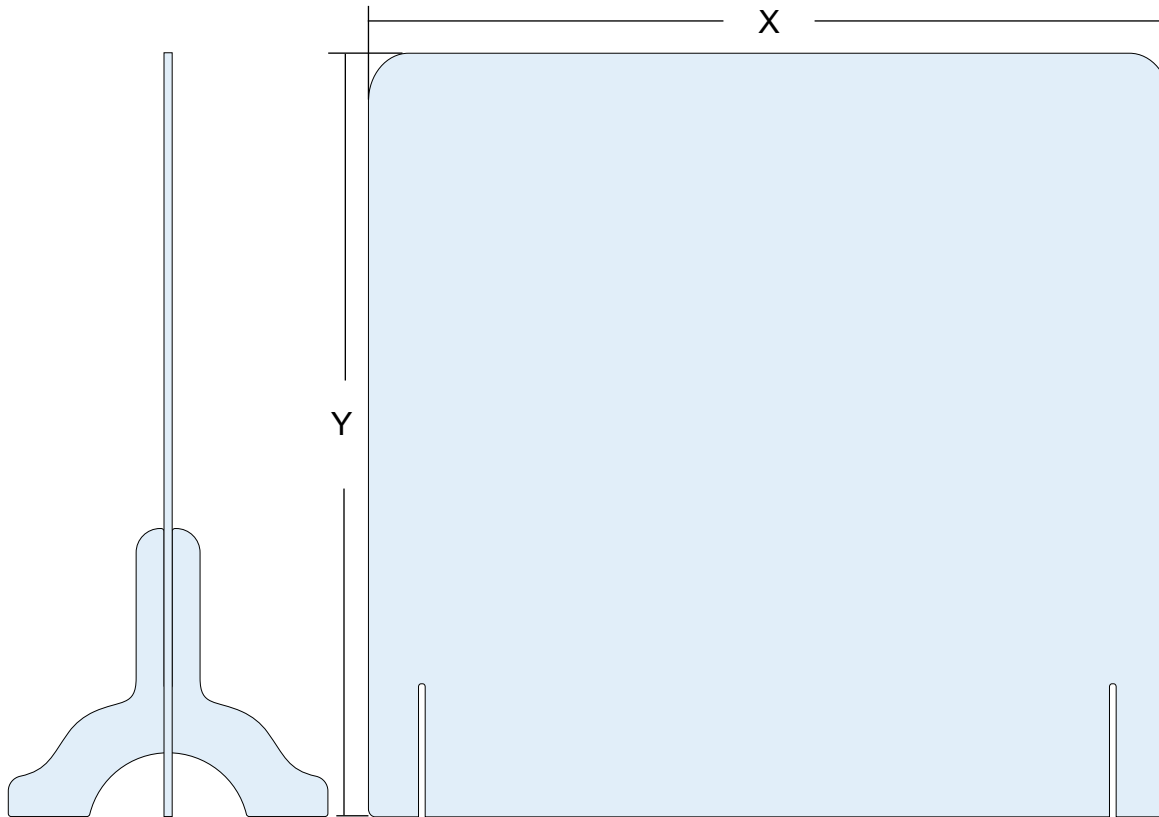

STANDARD SIZES:

Drawing (#)	Height (Y)	Length (X)	Feet Height (Y)	Feet Length (X)
SG-2236-F	22"	36"	14 9/16"	12 1/4"
SG-3268-F	32"	68"	14 9/16"	12 1/4"
SG-3236-F	32"	36"	14 9/16"	12 1/4"
SG-2430-F	24"	30"	9"	10"
SG-2036-F	20"	36"	14 9/16"	12 1/4"

Additional sizes available upon request, up to 40" height.





**ESSENTIAL™
WELLNESS
SHIELDS**

FREE STANDING MODELS

Section 1: SG-FR • SG-FRW (square top)

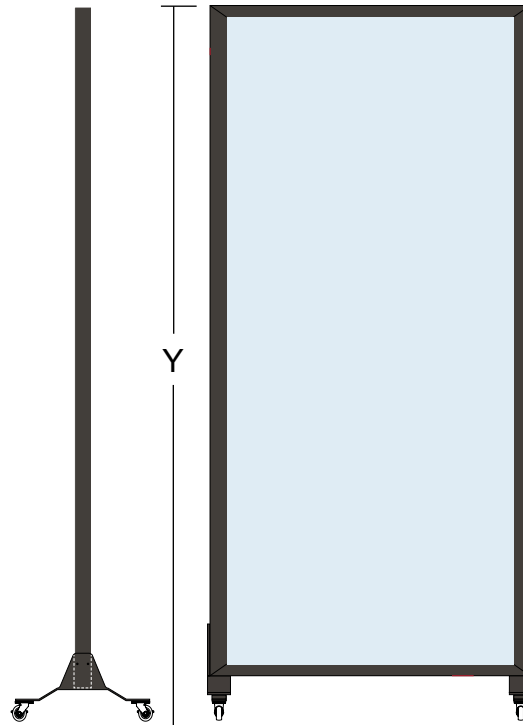
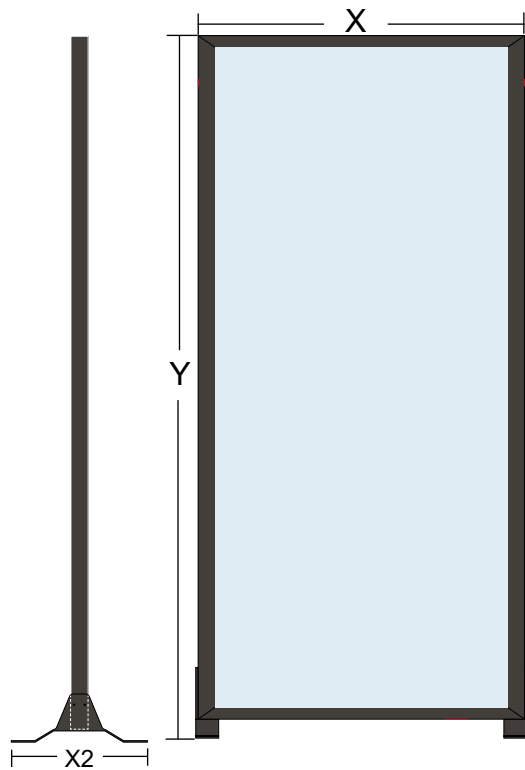
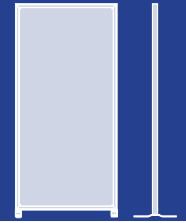

STANDARD SIZES:

Drawing (#)	Height (Y)	Length (X)	Feet Length (X2)	Wheels (YES/NO)
SG-7224-FR	72"	24"	18"	NO
SG-7224-FRW	72"	24"	18"	YES
SG-7236-FR	72"	36"	18"	NO
SG-7236-FRW	72"	36"	18"	YES
SG-7248-0-0X0FR-028	72"	48"	18"	NO

Additional sizes available upon request, up to 72" height.

These models come with our standard duranodic bronze painted aluminum HED-100 frame. Shape and bevel below:





**ESSENTIAL™
WELLNESS
SHIELDS**

FREE STANDING MODELS

Section 2: SG-RFR • SG-RFRW (radius top)

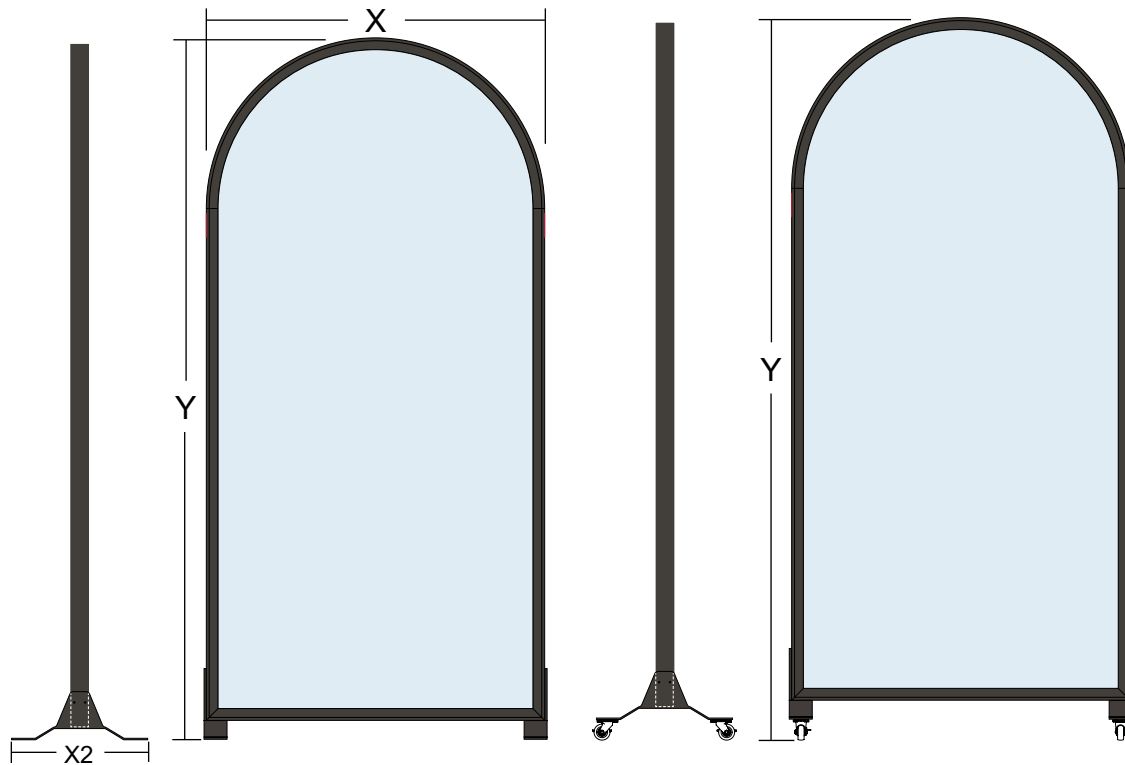
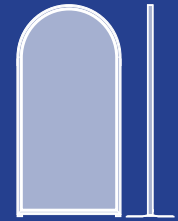

STANDARD SIZES:

Drawing (#)	Height (Y)	Length (X)	Feet Length (X2)	Wheels (YES/NO)
SG-7224-RFR	72"	24"	18"	NO
SG-7224-RFRW	72"	24"	18"	YES
SG-7236-RFR	72"	36"	18"	NO
SG-7236-RFRW	72"	36"	18"	YES

Additional sizes available upon request, up to 72" height.

These models come with our standard duranodic bronze painted aluminum HED-100 frame. Shape and bevel below:





**ESSENTIAL™
WELLNESS
SHIELDS**

FREE STANDING MODELS

Section 3: SG-RFRTW (radius top)
Three Wheels

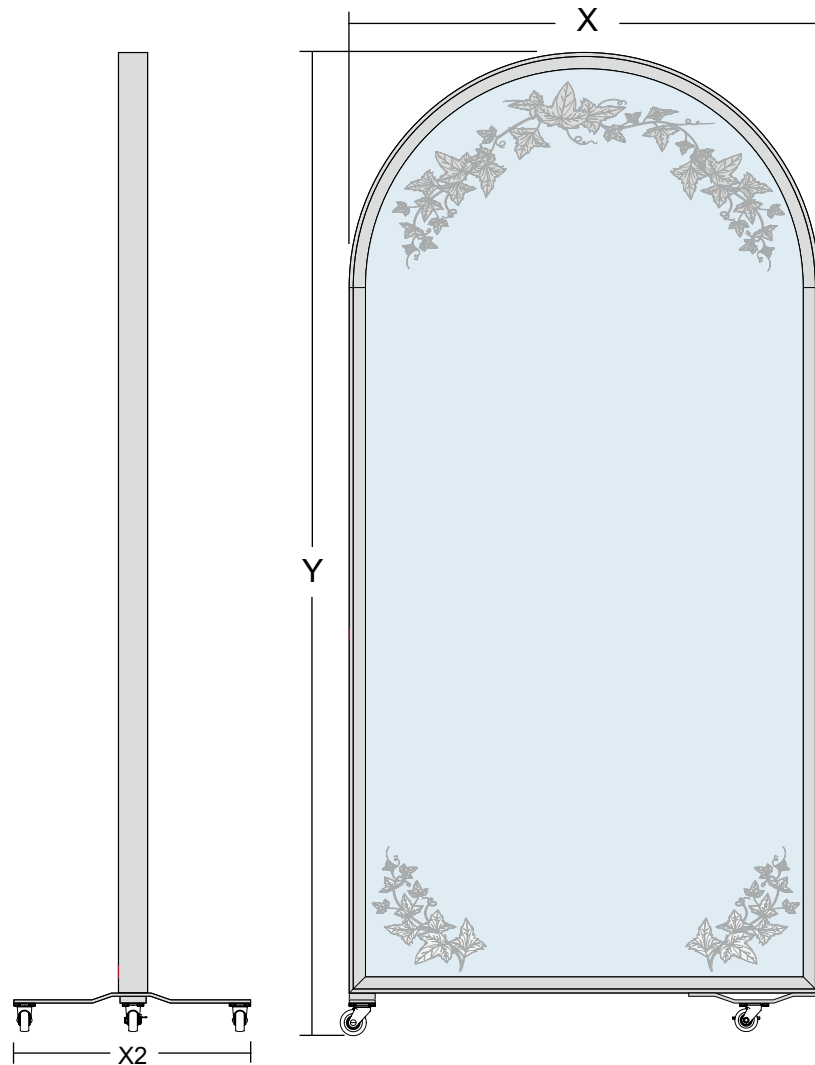
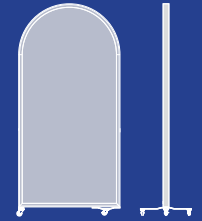

STANDARD SIZES:

Drawing (#)	Height (Y)	Length (X)	Feet Length (X2)	Wheels (YES/NO)
SG-7236-RFRTW	75"	36"	19"	YES

Additional sizes available upon request, up to 72" height.
Graphics optional.

These models come with our standard HED-100 frame. Shape and bevel below:





**ESSENTIAL
WELLNESS
SHIELDS**

“T” SHAPED TELLER MODELS WITH WINDOW

Section 1: SG-TW

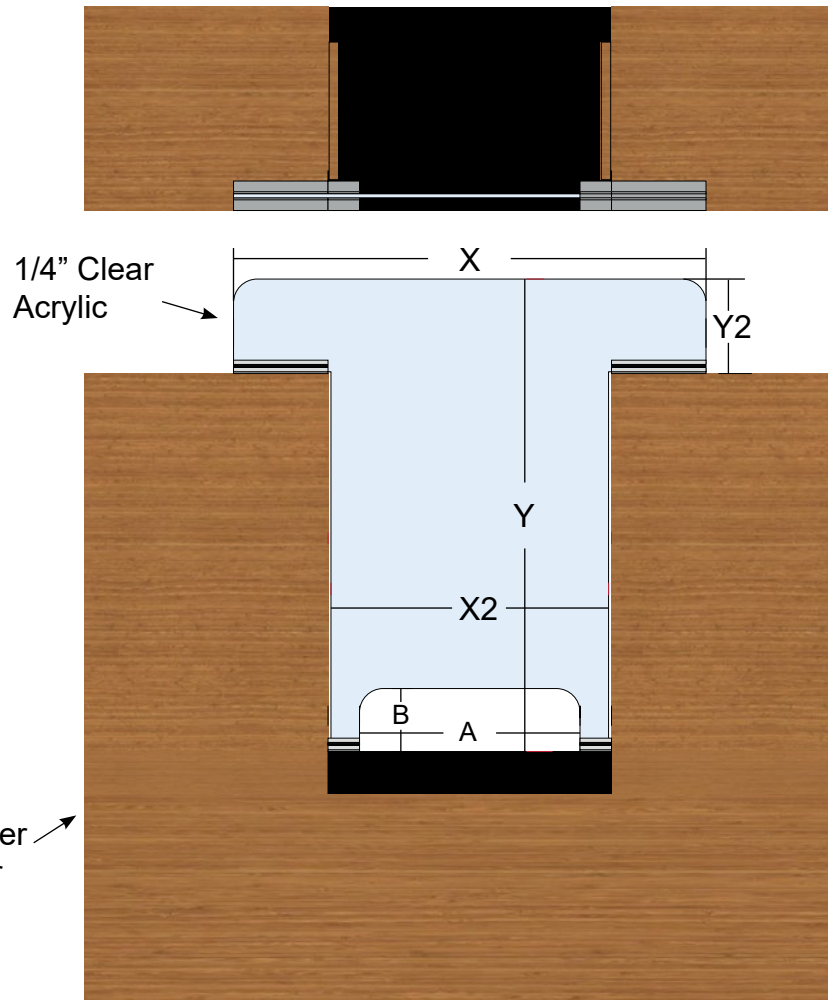

STANDARD SIZES:

Drawing (#)	Height (Y)	Length (X)	Height (Y2)	Length (X2)	Window Length (A)	Window Height (B)
SG-3018-TW	30"	30"	6"	18"	14"	4"
SG-3234-TW	32"	34"	15 3/4"	21 1/2"	14"	4"
SG-3017-TW	30"	26"	11 3/4" <small>*Left Side: 17 3/4"</small>	16 1/2"	11 1/2"	4"
SG-3020-TW	30"	30"	15 1/2"	19 1/2"	12 1/2"	4"
SG-3030-TW15_375x17	30"	26"	14 1/8"	16 1/2"	11 1/2"	4"
SG-3030-TW14X21	30"	30"	15 3/4"	20 1/2"	13 1/2"	4"
SG-3060-TW	30"	60"	18 1/8"	32 1/8"	28 1/8"	4"
SG-3616-TW	36"	28"	24"	15 5/8"	11 5/8"	4"
SG-3617_625-TW	36"	36"	24"	17 1/4"	13 1/4"	4"
SG-3615_625-TW	36"	36"	24"	15 1/4"	11 1/4"	4"
SG-43_516-TW	43 1/2"	28"	31 1/2"	15 5/8"	11 5/8"	4"
SG-3618-TW	36"	30"	19 7/8"	17 5/8"	13 5/8"	4"

Additional sizes available upon request.





**ESSENTIAL™
WELLNESS
SHIELDS**

STATIONARY MODELS

Section 1: SG-CTB (*counter mount*)

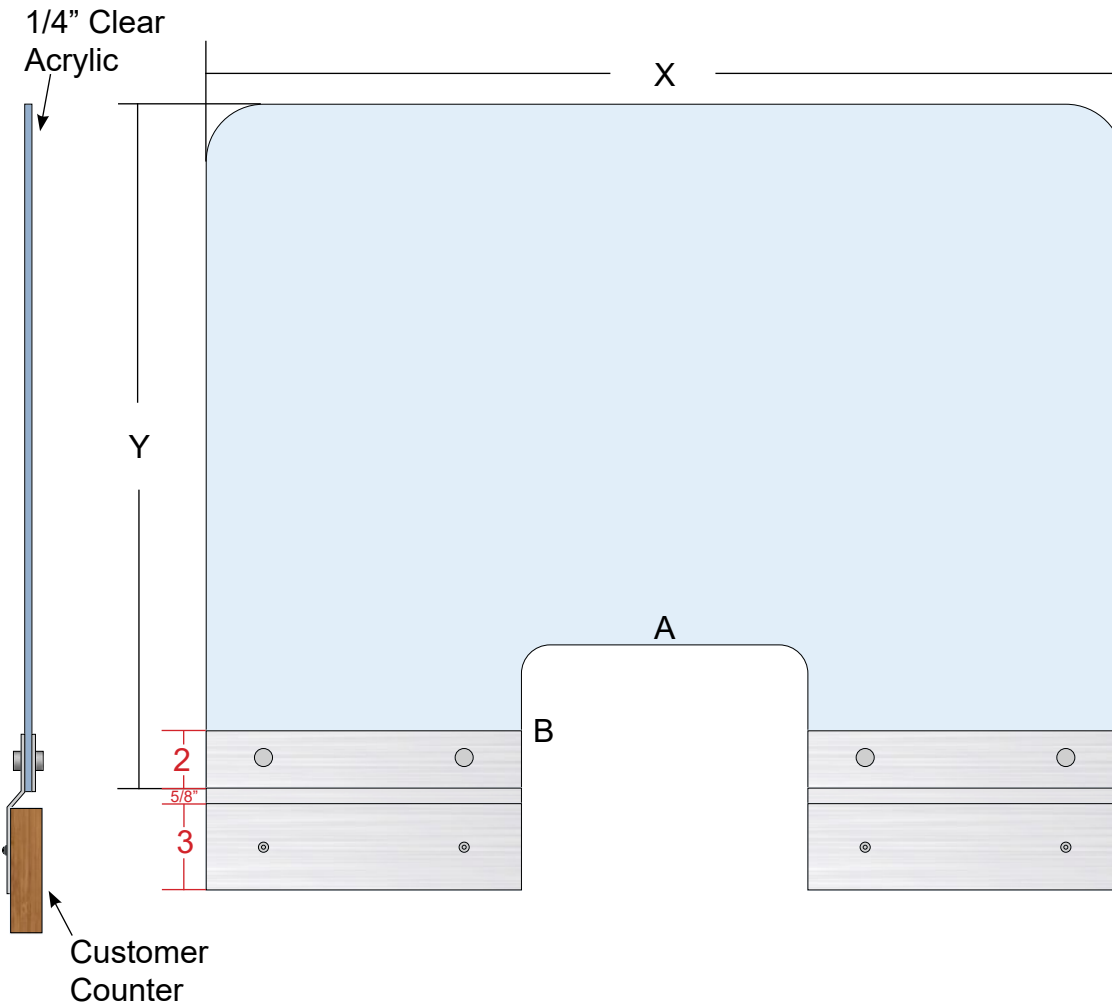
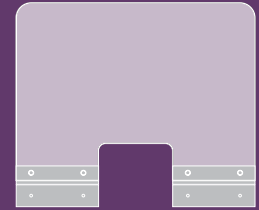

STANDARD SIZES:

Drawing (#)	Height (Y)	Length (X)	Window Length (A)	Window Height (B)
SG-2432-CTB	24"	32"	10"	5"
SG-3232-CTB	32"	32"	10"	5"
SG-3224-CTB	32"	24"	10"	5"

Additional sizes available upon request, up to 40" height.



**ESSENTIAL™
WELLNESS
SHIELDS**

STATIONARY MODELS

Section 2: SG-PM (*projection mount*)



1/4" Clear
Acrylic

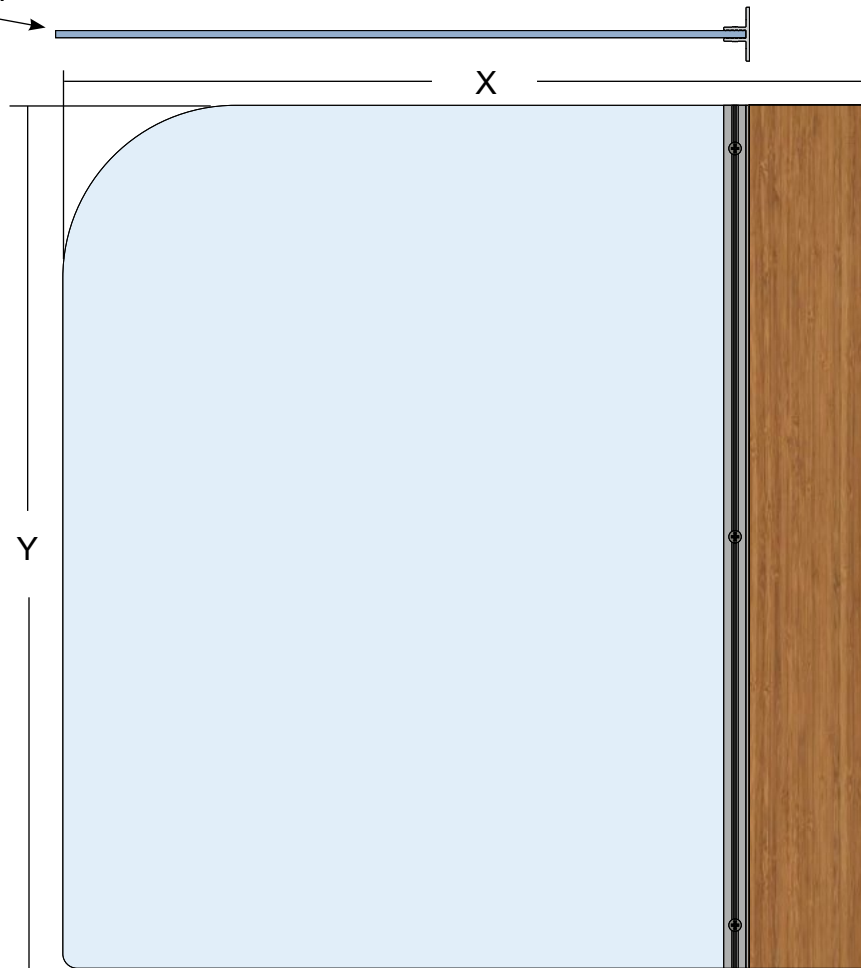

STANDARD SIZES:

Drawing (#)	Height (Y)	Length (X)
SG-3024-PM	30"	24"

Additional sizes available upon request.

Customer
Mounting
Surface



**ESSENTIAL™
WELLNESS
SHIELDS**

STATIONARY MODELS

Section 3: SG-CM (ceiling mount)

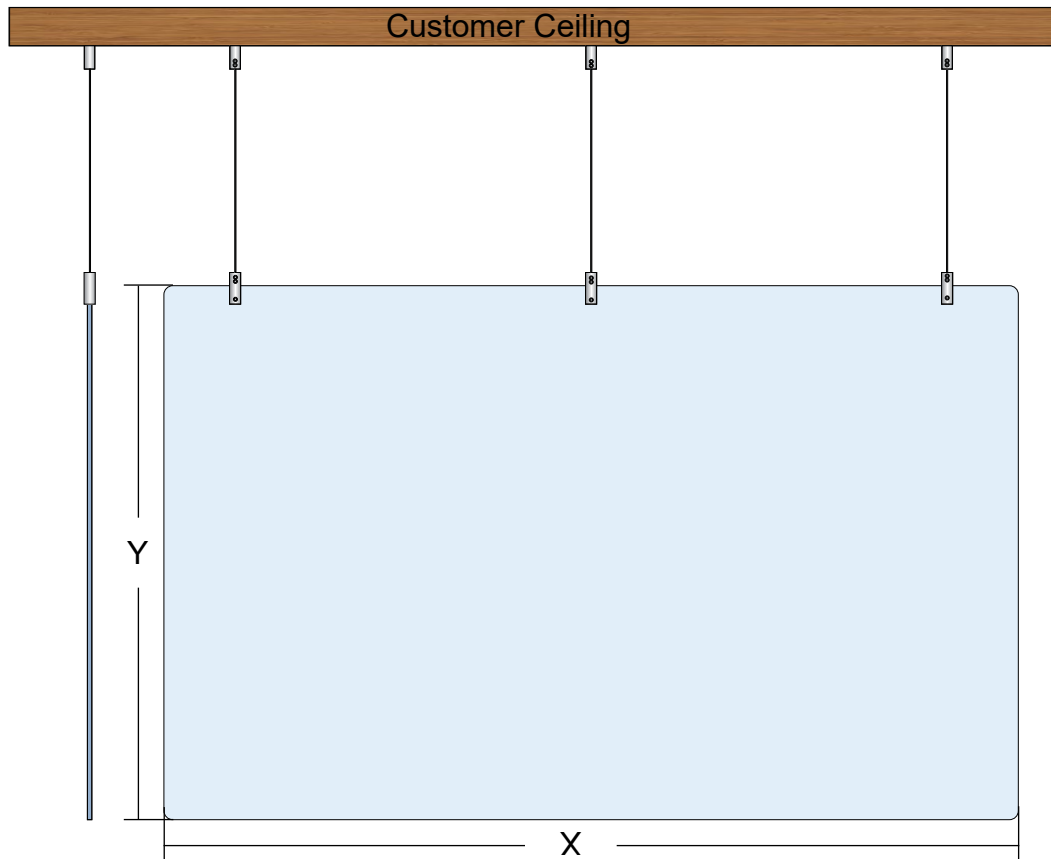
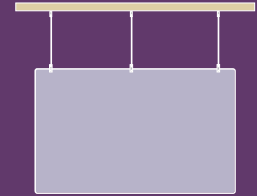

STANDARD SIZES:

Drawing (#)	Height (Y)	Length (X)
SG-3048-CM	30"	48"
SG-3036-CM	30"	36"
SG-3024-CM	30"	24"

Additional sizes available upon request.
Size of panel dictates number of standoffs.



**ESSENTIAL
WELLNESS
SHIELDS**

STATIONARY MODELS

Section 3: SG-CM (ceiling mount)

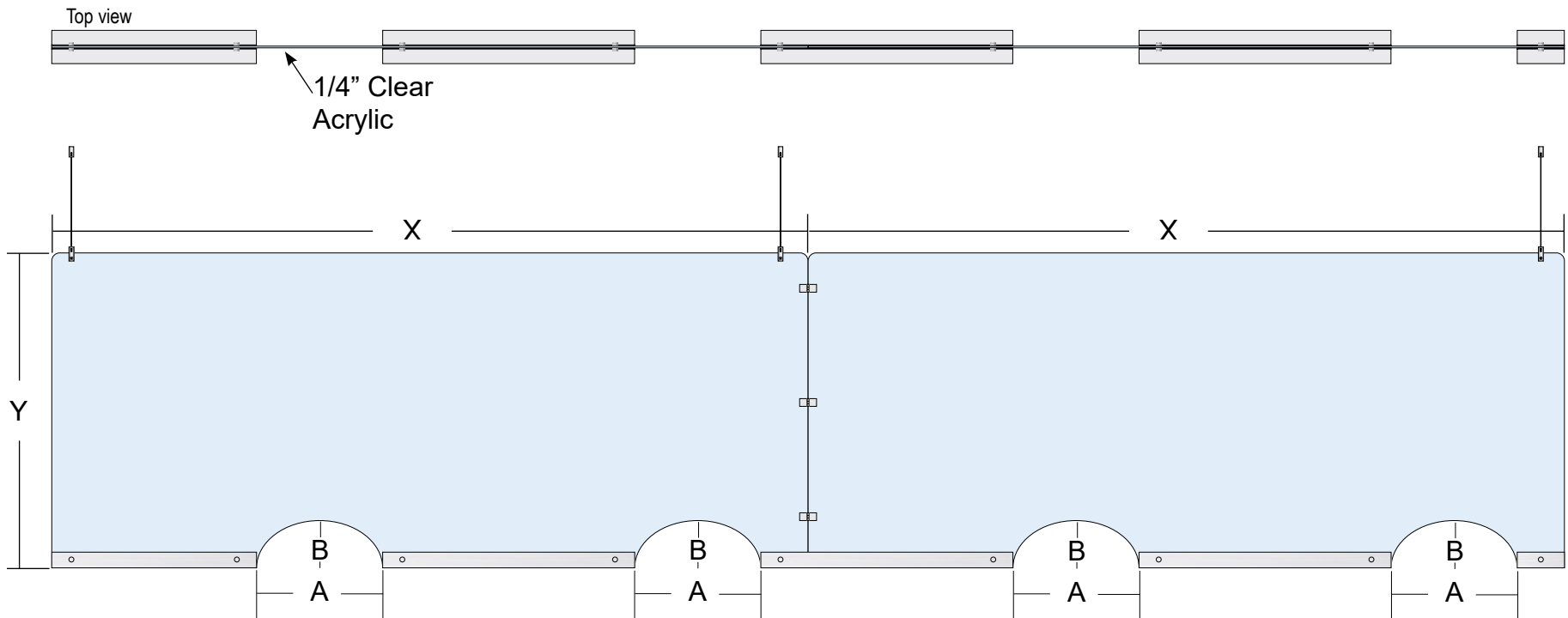
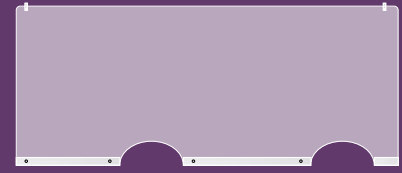

Additional sizes available upon request up to 40" height.

For sizes 40" and higher.
3" angle replaces the 2" for the mounting base

STANDARD SIZES:

Drawing (#)	Height (Y)	Length (X)	Window Height (B)	Window Length (A)	Overall Width (C)
SG-9640-CCM	40"	96"	6"	16"	64"



**ESSENTIAL
WELLNESS
SHIELDS**

STATIONARY MODELS

Section 4: SG-P (*all acrylic*)

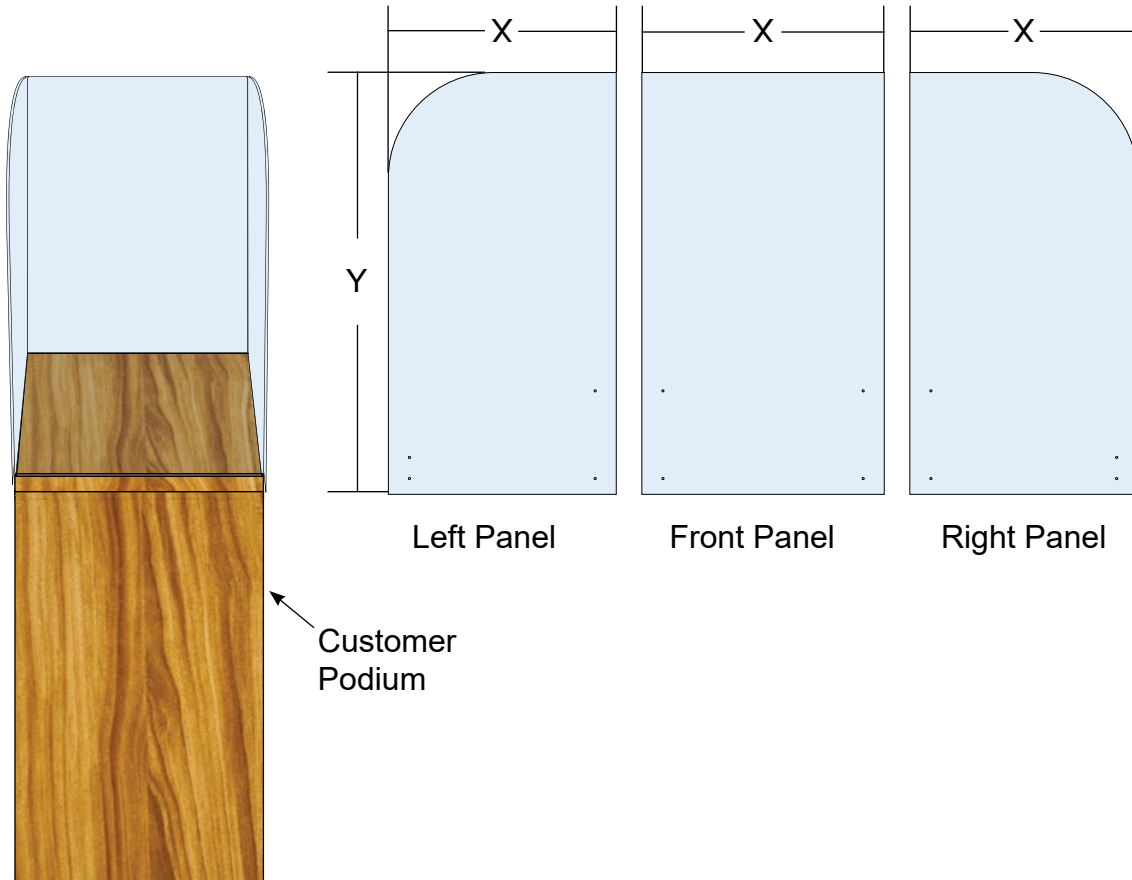
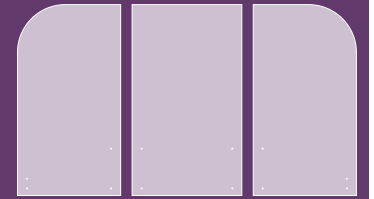

STANDARD SIZES:

Drawing (#)	Front Panel Height (Y)	Front Panel Length (X)	Left/Right Height (Y)	Left/Right Length (X)
SG-4024-P	40"	23"	40"	21 5/8"

Additional sizes available upon request.



**ESSENTIAL™
WELLNESS
SHIELDS**

STATIONARY MODELS

Section 4: All Acrylic

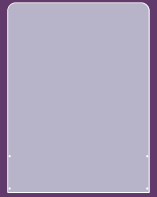

1/4" Clear
Acrylic

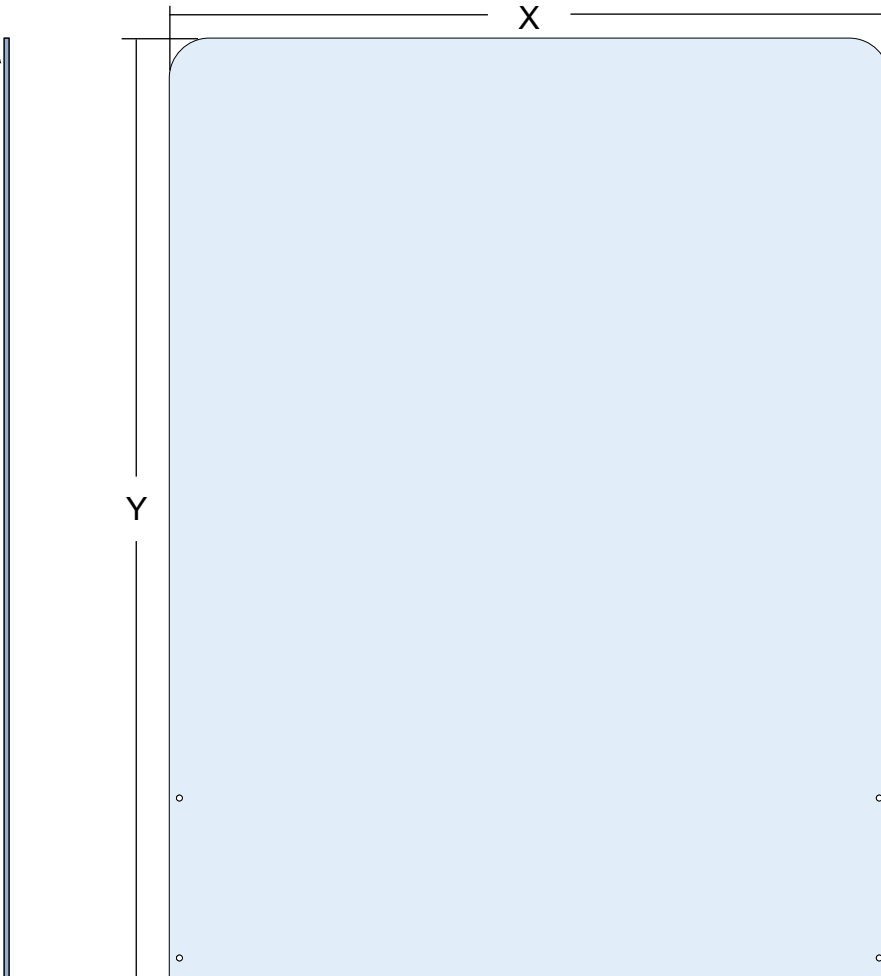

STANDARD SIZES:

Drawing (#)	Height (Y)	Length (X)
SG-4736-AC	47"	36"

Additional sizes available upon request.



**ESSENTIAL™
WELLNESS
SHIELDS**

STATIONARY MODELS

Section 5: Cubicle Mount

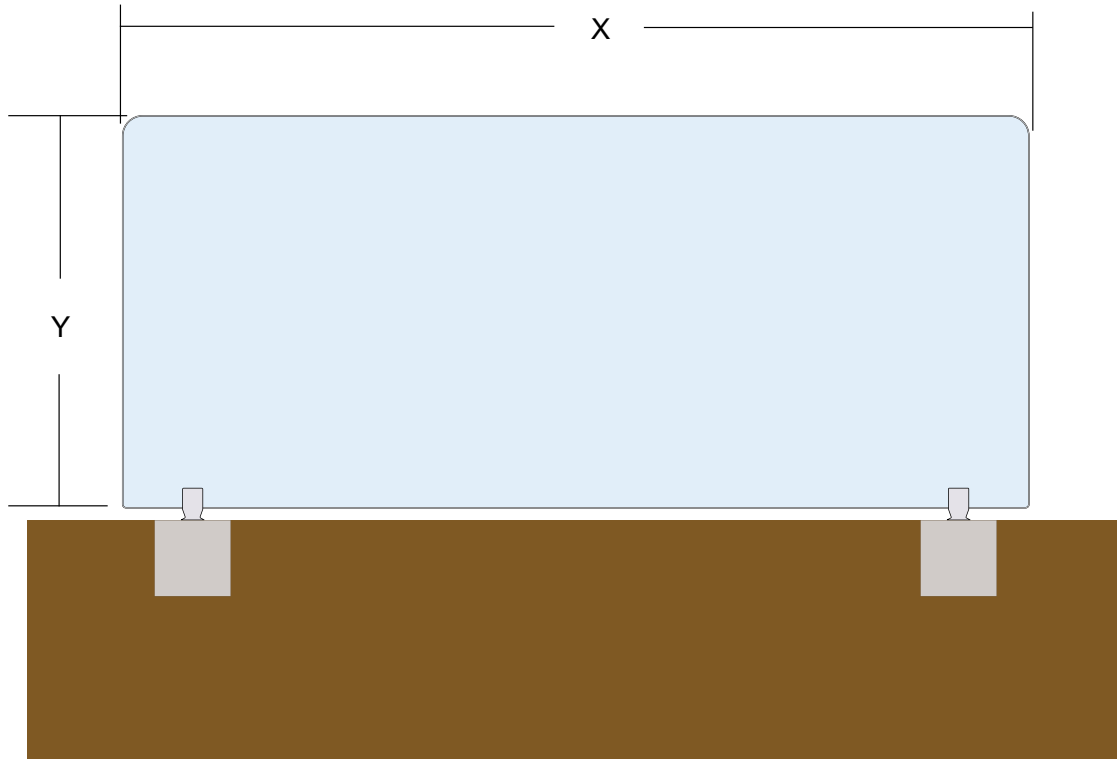

Drawing (#)	Height (Y)	Length (X)
SG-Cubicle	18"	48"

The size listed above is the MAX amount possible for this model. Height (Y) ranges from 12"-18".
Additional sizes available for this model.



**ESSENTIAL™
WELLNESS
SHIELDS**

TABLE DIVIDER MODELS

Section 1: SG-TBLD4 (4 sections)

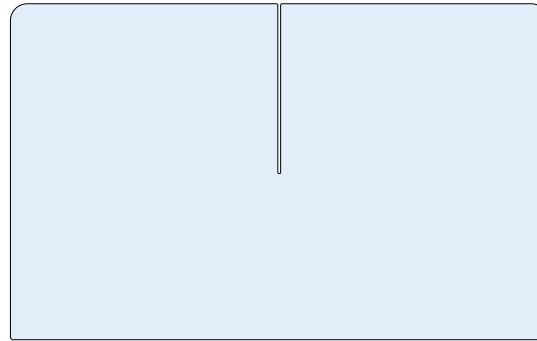
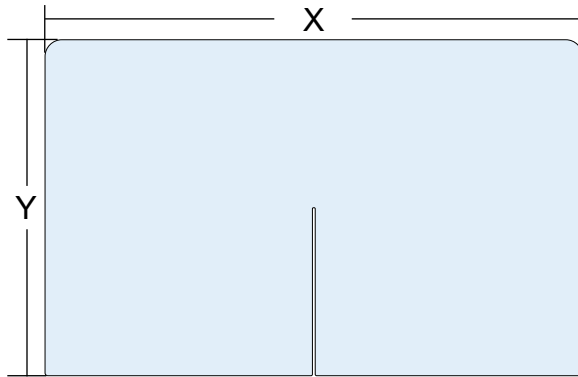
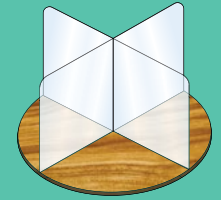

STANDARD SIZES:

Drawing (#)	Height (Y)	Length (X)
SG-3048-0-0x0-TBLD4-760	30"	48"

Additional sizes available upon request.

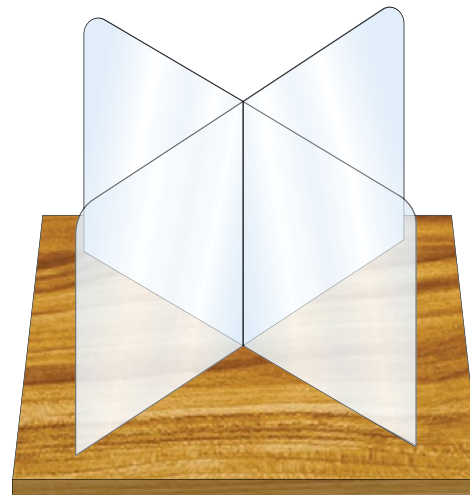
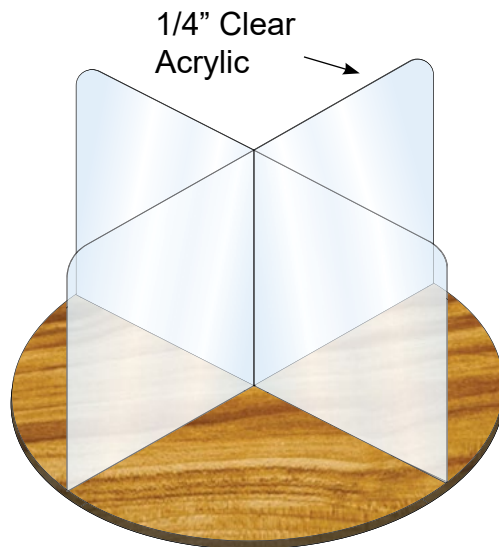

* Not drawn to scale.



**ESSENTIAL™
WELLNESS
SHIELDS**

TABLE DIVIDER MODELS

Section 1: SG-TBLD4 (4 sections)
With Windows

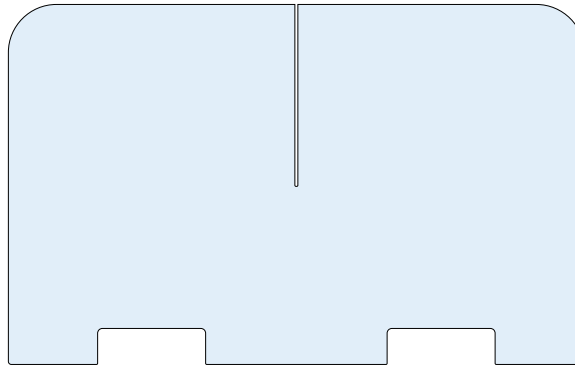
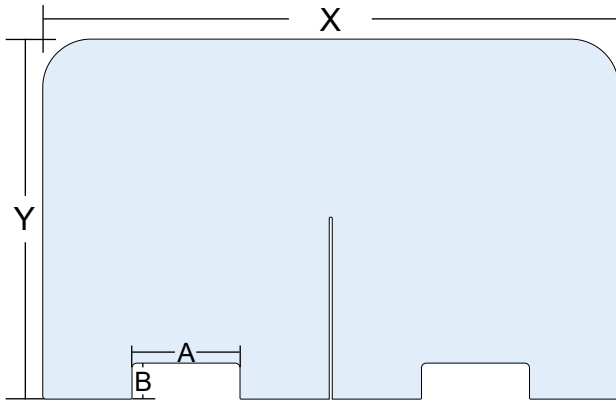
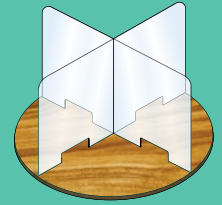

STANDARD SIZES:

Drawing (#)	Height (Y)	Length (X)	Window Length (A)	Window Height (B)
SG-3048-4-3x9-TBLD4-754	30"	48"	9"	3"

Additional sizes available upon request.

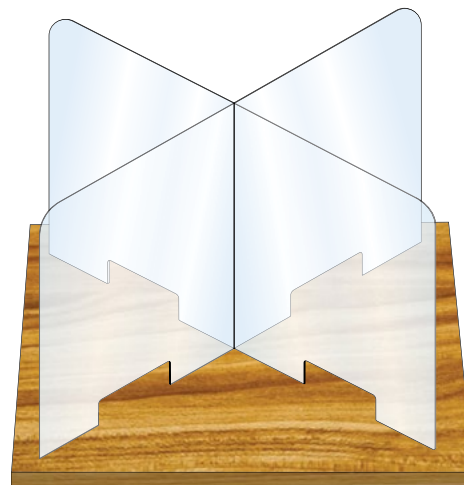
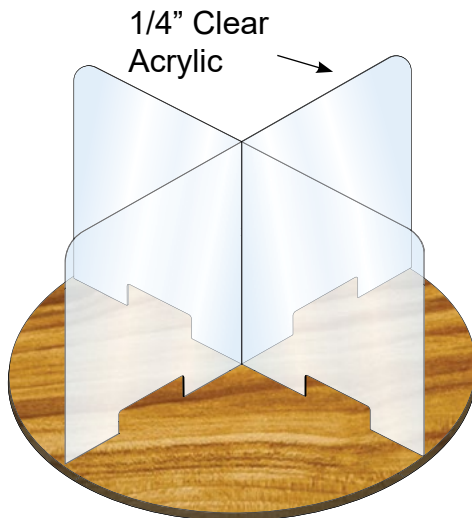

* Not drawn to scale.



**ESSENTIAL™
WELLNESS
SHIELDS**

TABLE DIVIDER MODELS

Section 2: SG-TBLD6 (6 sections)

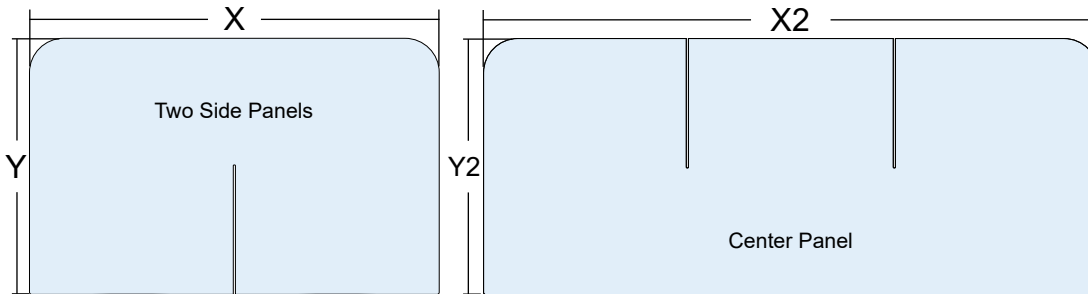
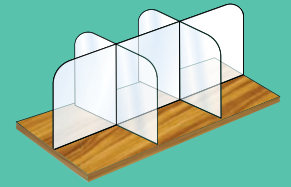

STANDARD SIZES:

Drawing (#)	Side Panel Length (X)	Side Panel Height (Y)	Center Panel Length (X2)	Center Panel Length (X2)
SG-3048-0-0x0-TBLD6-760	48"	30"	72"	30"
SG-3872-0-0x0-TBLD6-773	38"	30"	72"	30"

Additional sizes available upon request.

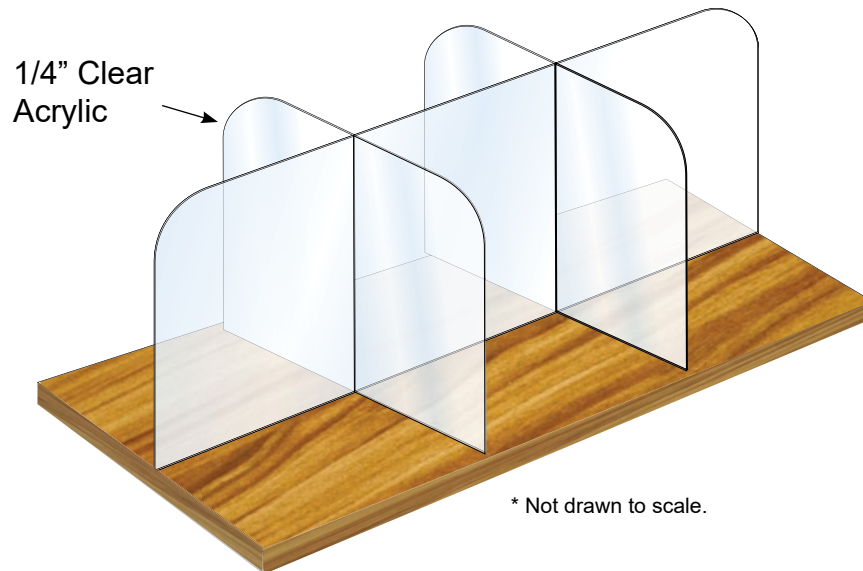

* Not drawn to scale.



**ESSENTIAL™
WELLNESS
SHIELDS**

TABLE DIVIDER MODELS

Section 3: SG-TBLD8 (8 sections)

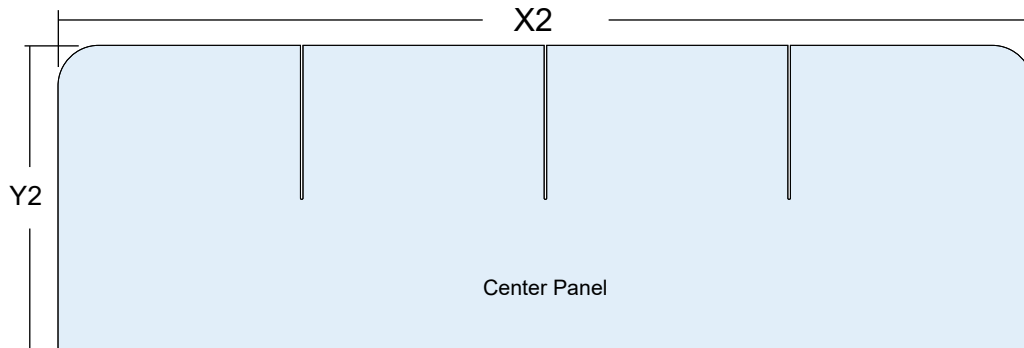
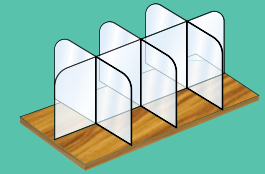

STANDARD SIZES:

Drawing (#)	Side Panel Length (X)	Side Panel Height (Y)	Center Panel Length (X2)	Center Panel Length (X2)
SG-3048-0-0x0-TBLD8-760	48"	30"	96"	30"

Additional sizes available upon request.

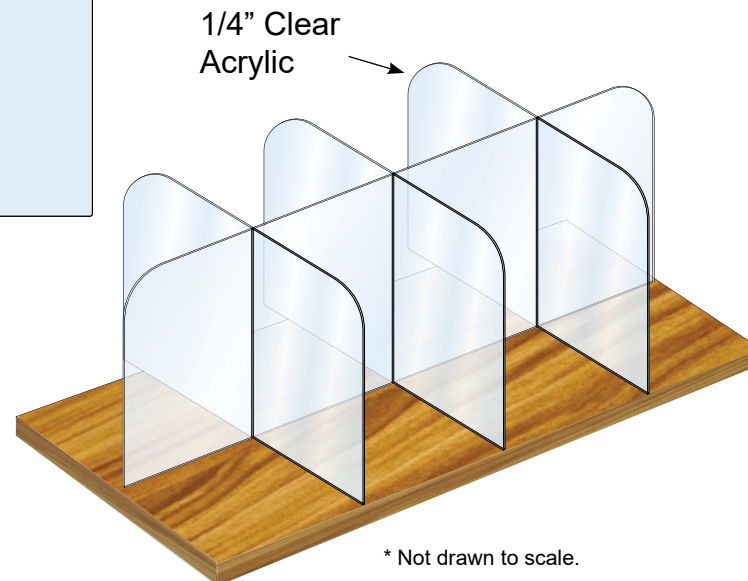
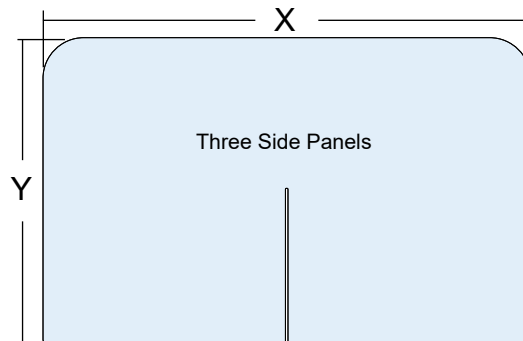

* Not drawn to scale.



**ESSENTIAL™
WELLNESS
SHIELDS**

VEHICLE MODELS WITH WINDOWS

Section 1: SUV

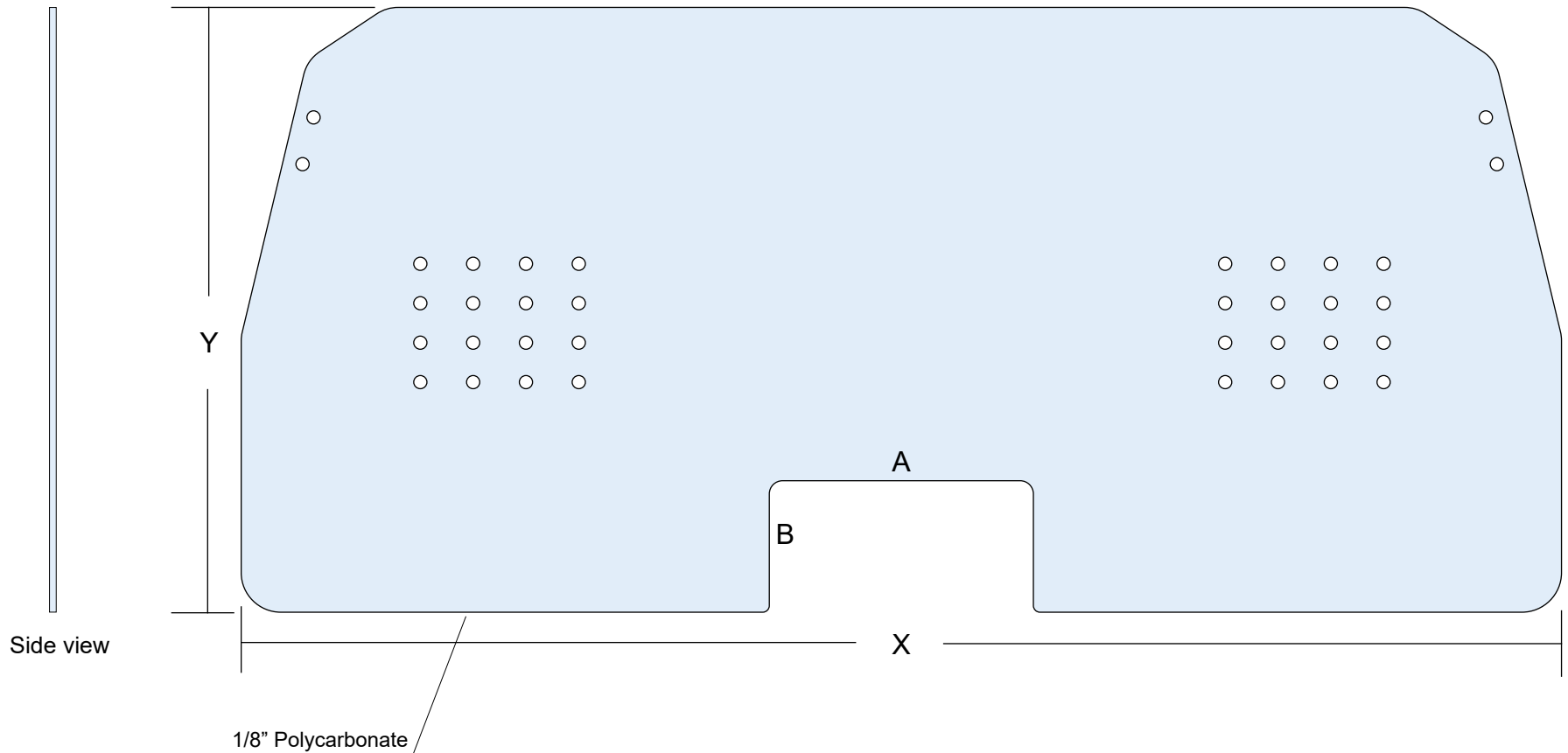

STANDARD SIZES:

Drawing (#)	Height (Y)	Length (X)	Window Height (B)	Window Length (A)
SG-2350-1-5x10-SUV-488	23"	50"	5"	10"

Additional options for side and bottom bends



**ESSENTIAL™
WELLNESS
SHIELDS**

VEHICLE MODELS WITH WINDOWS

Section 1: SUV

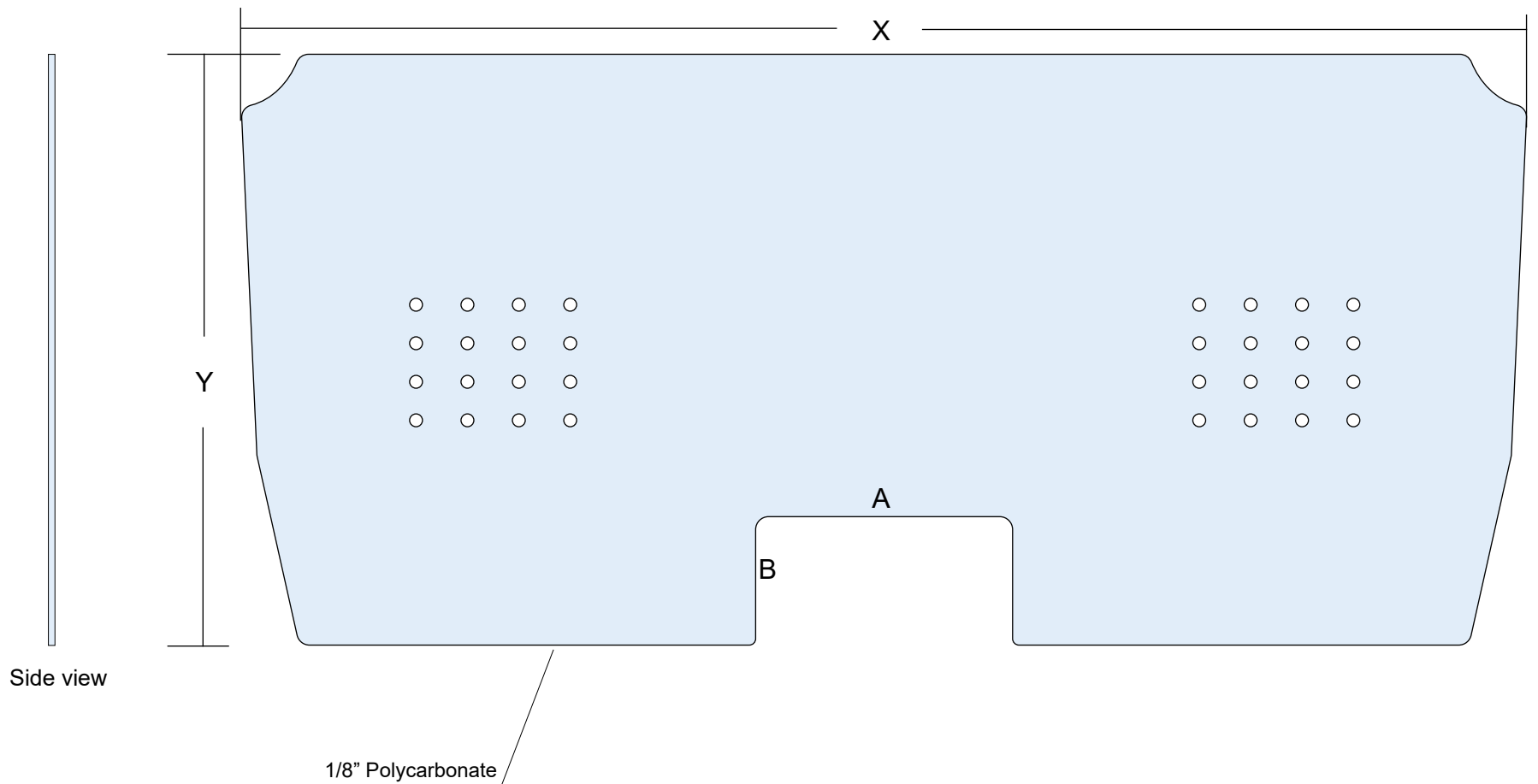

STANDARD SIZES:

Drawing (#)	Height (Y)	Length (X)	Window Height (B)	Window Length (A)
SG-2350-1-5x10-SUV-498	23"	50"	5"	10"

Additional options for side and bottom bends



**ESSENTIAL™
WELLNESS
SHIELDS**

VEHICLE MODELS WITH WINDOWS

Section 2: Car

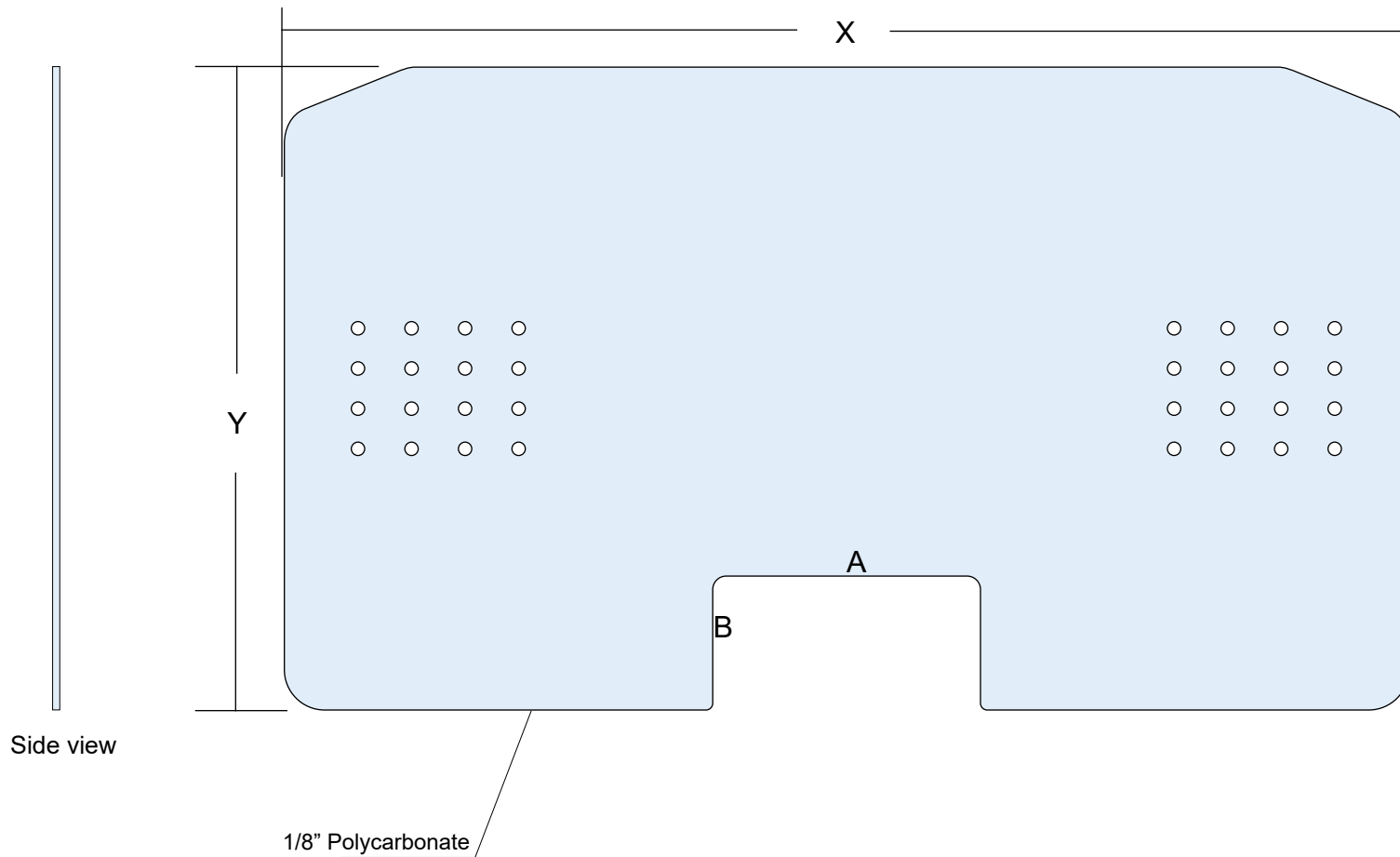

STANDARD SIZES:

Drawing (#)	Height (Y)	Length (X)	Window Height (B)	Window Length (A)
SG-2442-1-5x10-CAR-486	24"	42"	5"	10"

Additional options for side and bottom bends



**ESSENTIAL™
WELLNESS
SHIELDS**

VEHICLE MODELS WITH WINDOWS

Section 2: Car

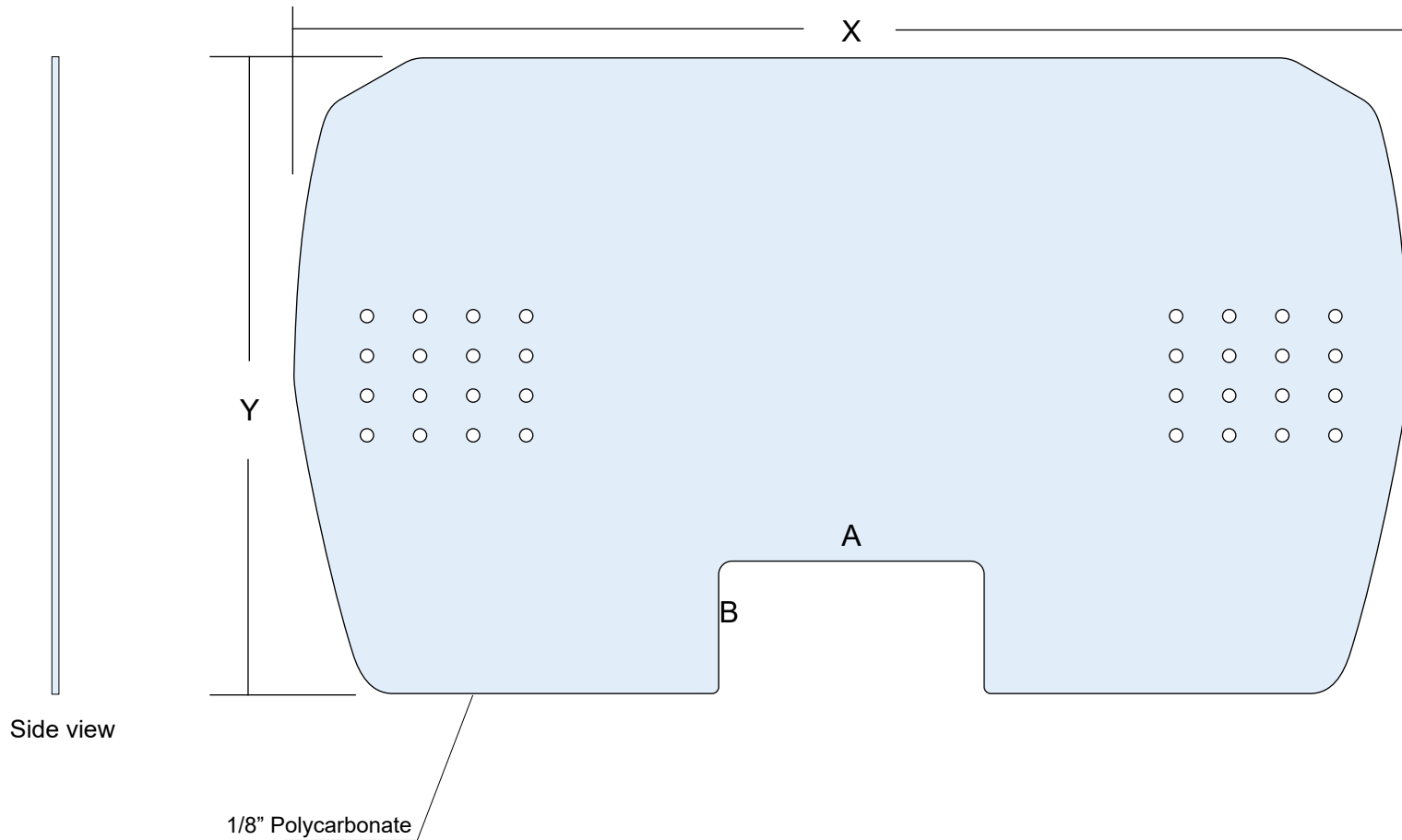

STANDARD SIZES:

Drawing (#)	Height (Y)	Length (X)	Window Height (B)	Window Length (A)
SG-2442-1-5x10-CAR-487	24"	42"	5"	10"

Additional options for side and bottom bends



**ESSENTIAL
WELLNESS
SHIELDS**

VEHICLE MODELS WITH WINDOWS

Section 3: Truck

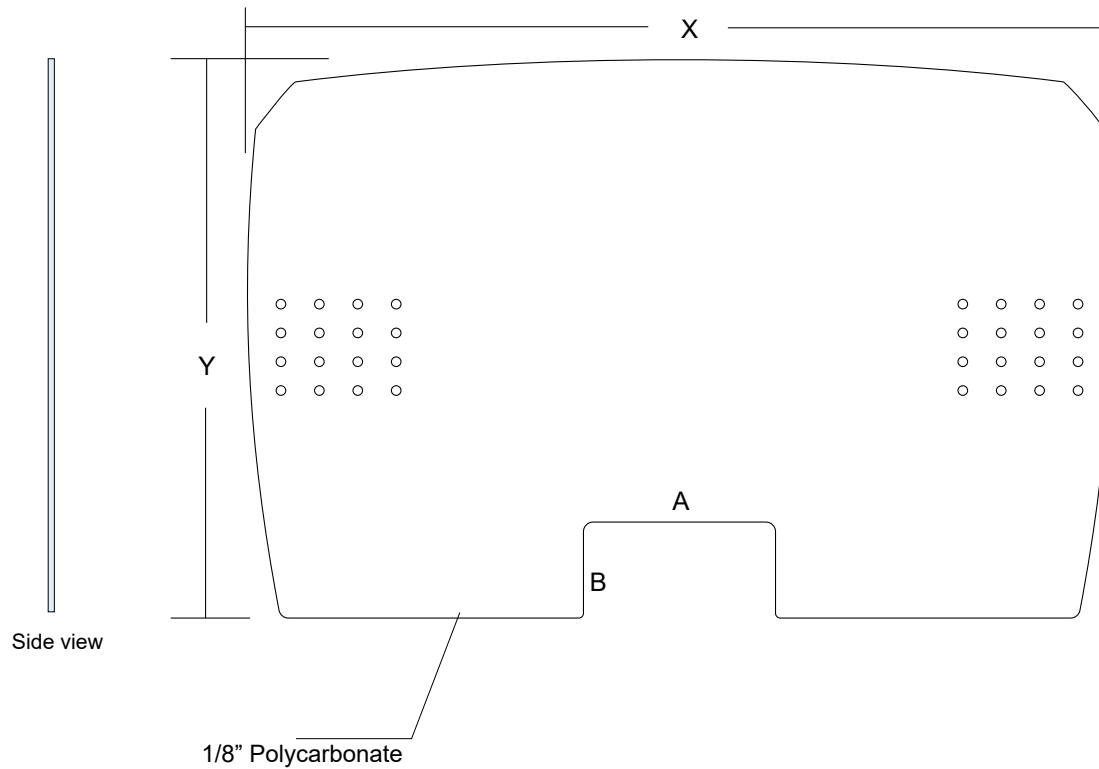

STANDARD SIZES:

Additional options for side
and bottom bends

Drawing (#)	Height (Y)	Length (X)	Window Height (B)	Window Length (A)
SG-TRUCK-Model	29"	45"	5"	10"



**ESSENTIAL™
WELLNESS
SHIELDS**

VEHICLE MODELS WITH WINDOWS

Section 4: Mini Van

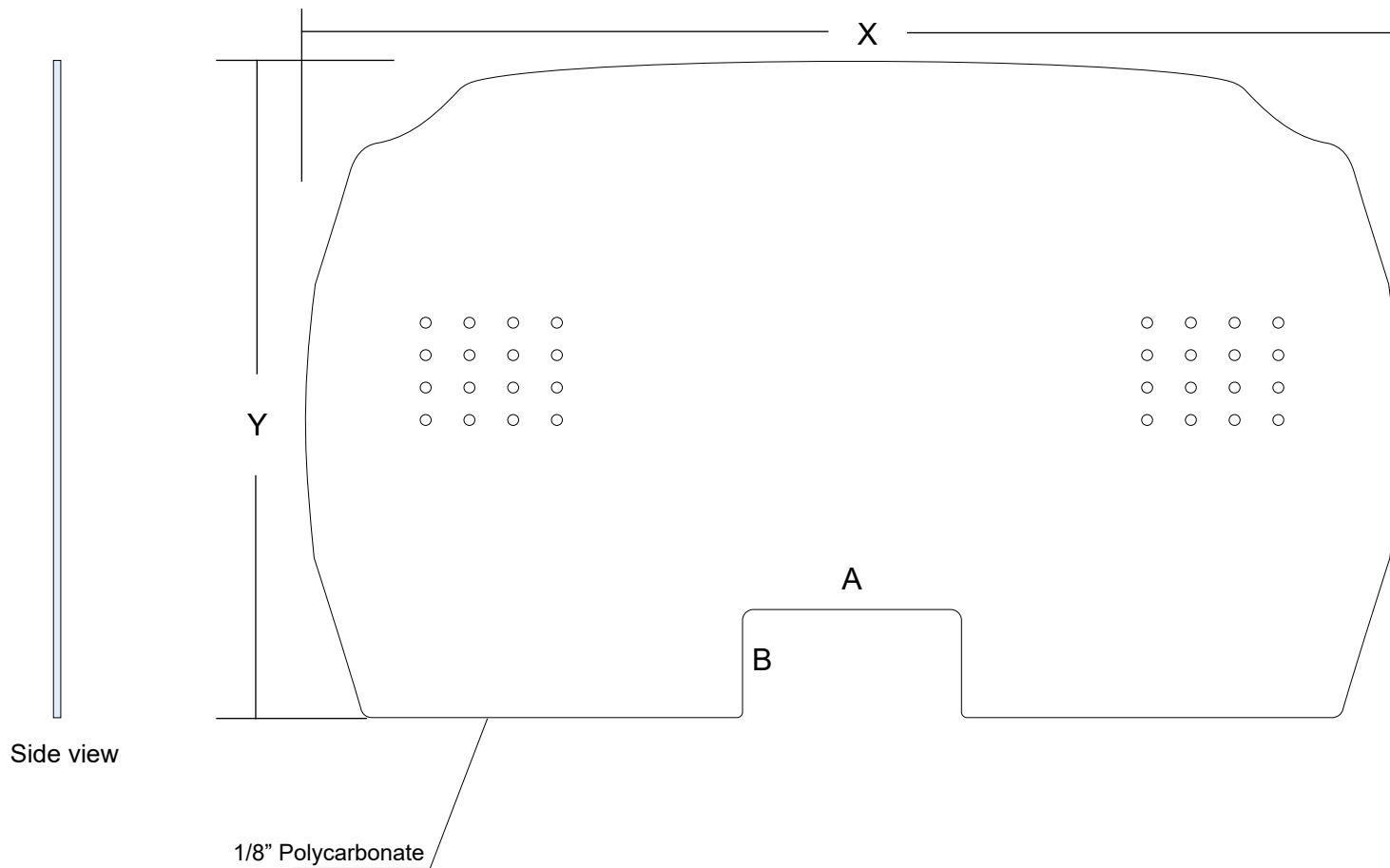

Side view

1/8" Polycarbonate

STANDARD SIZES:

Drawing (#)	Height (Y)	Length (X)	Window Height (B)	Window Length (A)
SG-MiniVan-Model	30"	50"	5"	10"

Additional options for side and bottom bends



814.833.7000 (local)
877.468.7000 (toll free)

primesignprogram.com

6400 Howard Drive

Fairview, PA 16415